

الحمادي للإلكترونيات
ALHAMMADI FOR ELECTRONICS

8 Channel 5V Relay Module

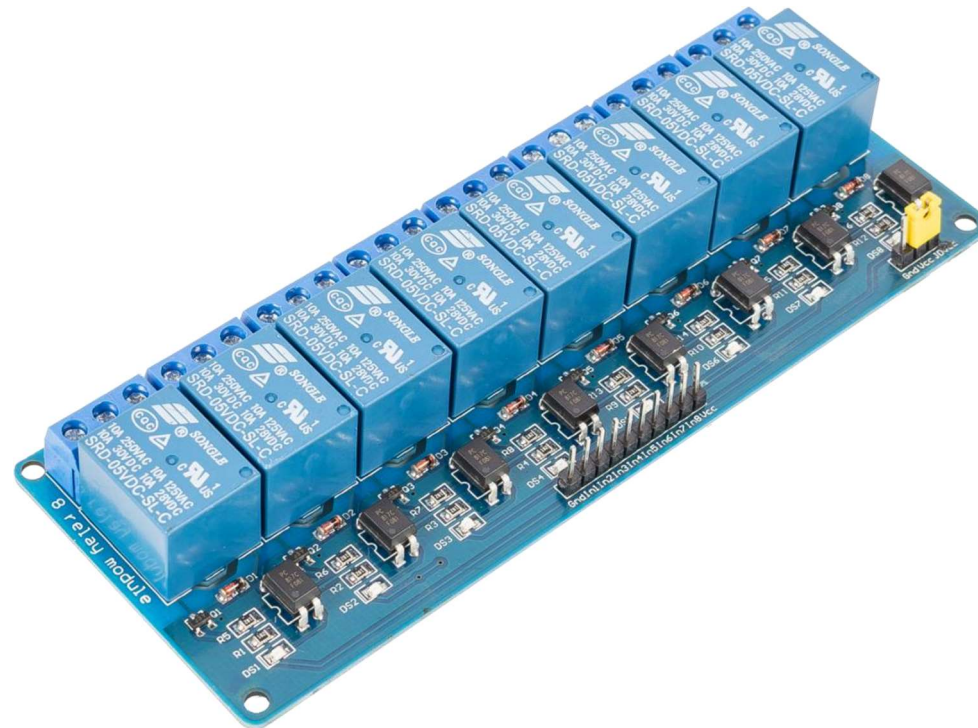

This is a LOW Level 5V 8-channel relay interface board, and each channel needs a 15-20mA driver current. It can be used to control various appliances and equipment with large current. It is equipped with high-current relays that work under AC250V 10A or DC30V 10A. It has a standard interface that can be controlled directly by micro-controller.

Features

- Power Supply Voltage: 5VDC, 12VDC
- Current: Greater than 100mA
- Load: 250V 10A AC or 30V 10A DC
- Size: 134.6mm x 53.6mm x 19.5mm (LxWxH)
- Equipped with mounting holes around, hole diameter 3.1mm
- Relay Type: Single Pole Double Throw (SPDT)
- Optocoupler isolation, good anti-interference capability
- When input is at low level, the relay is off, and the indicator light is on.
- Standard interface that can be directly controlled by microcontroller (8051, AVR, PIC, DSP, ARM, MSP430, TTL logic)

Pinout

The module features a design that includes both input and output connections.

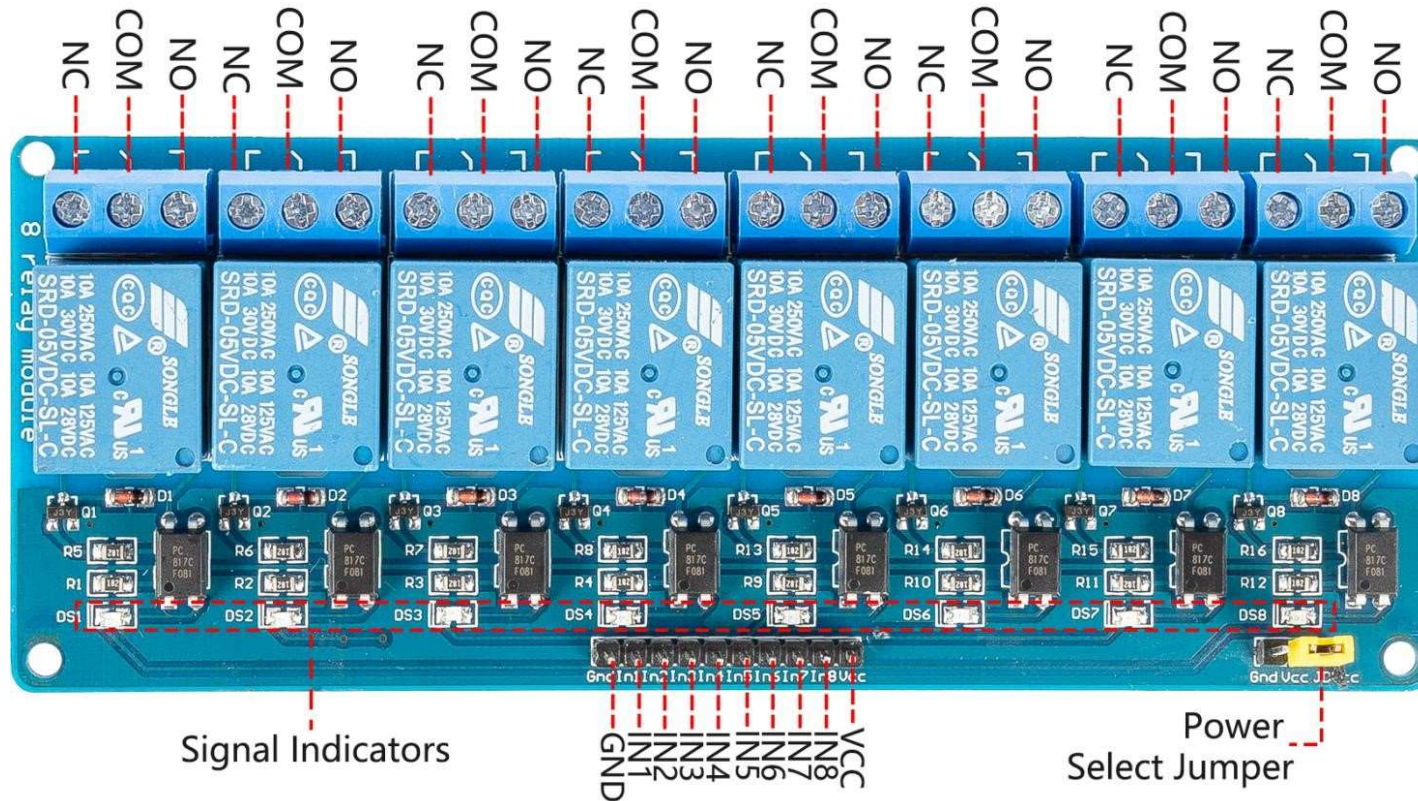

On the input side, where it receives the trigger signal, the connections typically include three or four pins, as outlined in the relay module circuit diagram:

- **VCC:** This is the positive power supply input from the main control.
- **GND:** Ground connection.
- **IN1~IN8:** The signal input pins for the relays. When a low-level signal is input, the Normally Open (NO) contact of the relay connects with the Common (COM) terminal.
- **JD-VCC:** This pin is for the relay's power supply. Connecting JD-VCC and VCC with a jumper cap indicates that the relay is powered by the main control board's power supply. Alternatively, an external power supply can be connected to this pin to power the relay.

On the output side, the relay module has three connections:

- **NO (Normally Open):** This is the load connection when the relay is active (ON). In the off state, NO is not connected to the COM (Common) terminal.
- **COM (Common):** This terminal serves as the common connection for both NO and NC (Normally Closed) pins.
- **NC (Normally Closed):** This is the default load connection, which is connected to the COM terminal when the relay is OFF or in its default state.

Schematic

VCC and JD-VCC are also the power supply of the relay module. When you need to drive a large power load, you can take the jumper cap off and connect an extra power to JD-VCC to supply the relay; connect VCC to 5V of the MCU board to supply input signals.

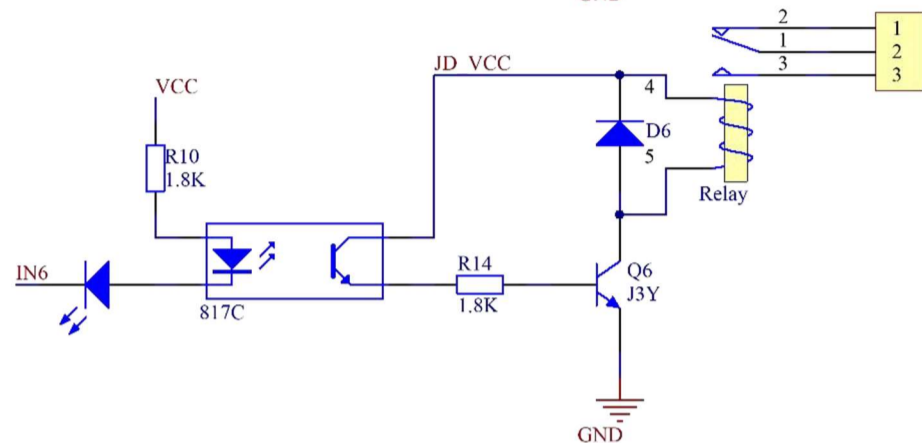
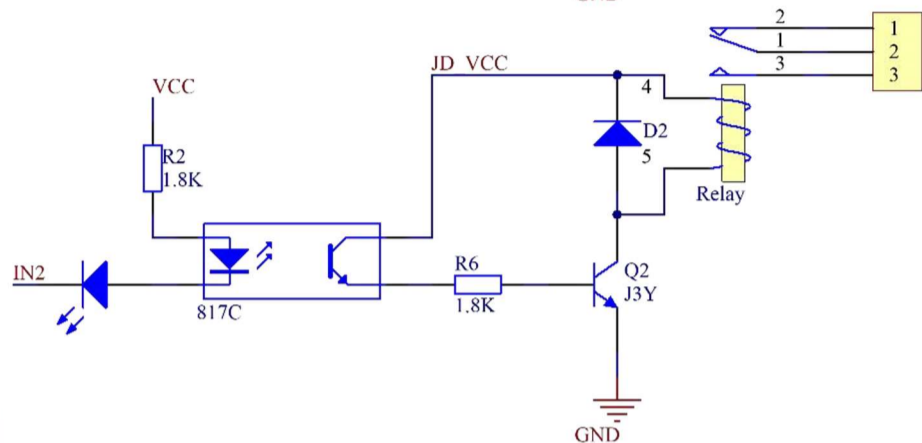
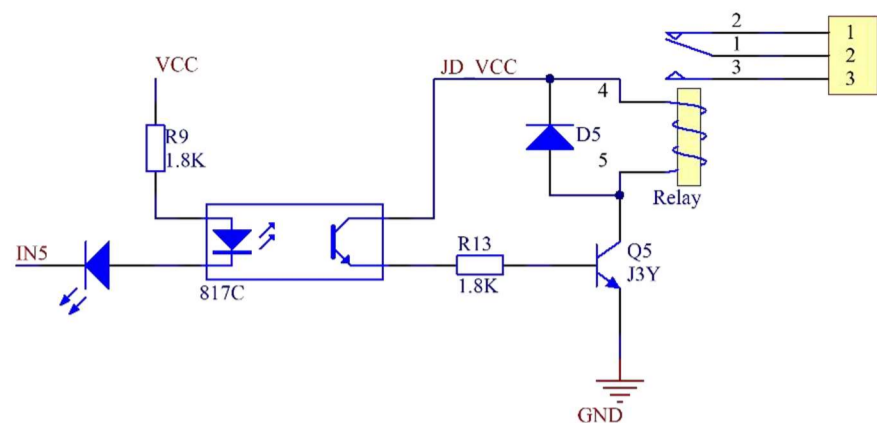
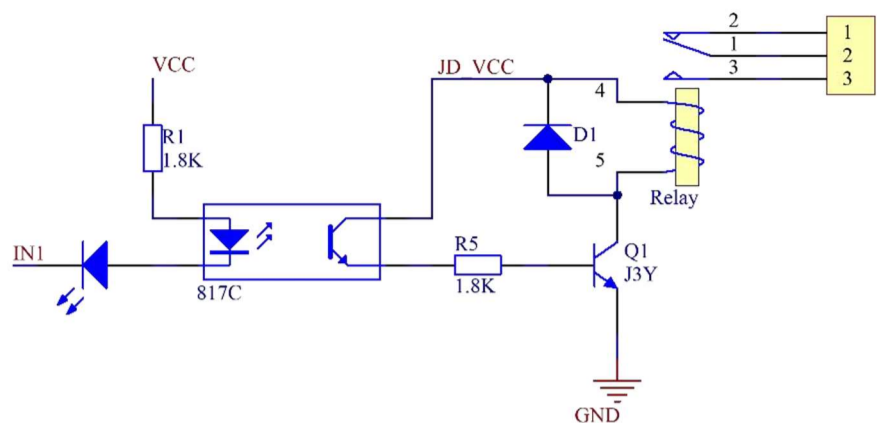

JD VCC	1
VCC	2
GND	3

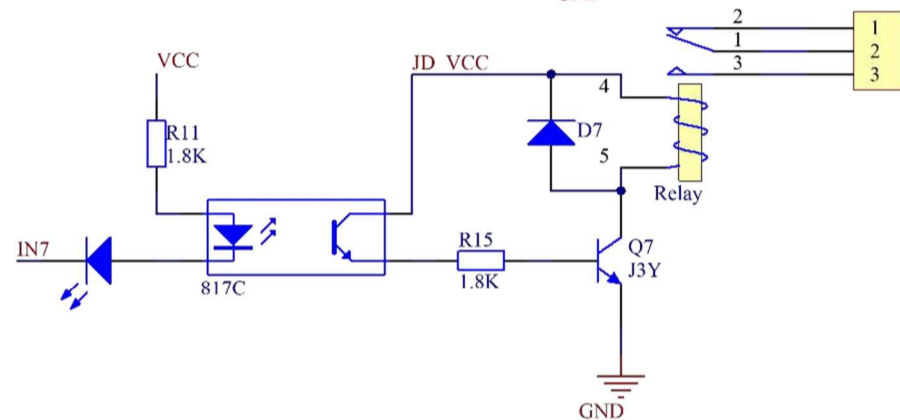
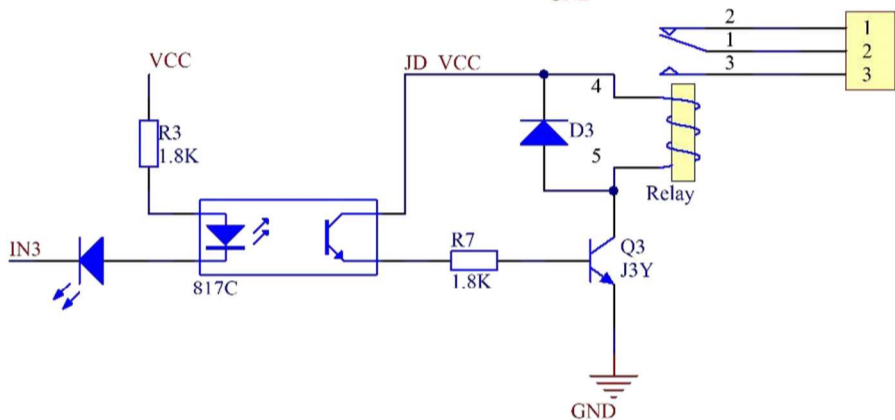

GND	1
IN1	2
IN2	3
IN3	4
IN4	5
IN5	6
IN6	7
IN7	8
IN8	9
VCC	10

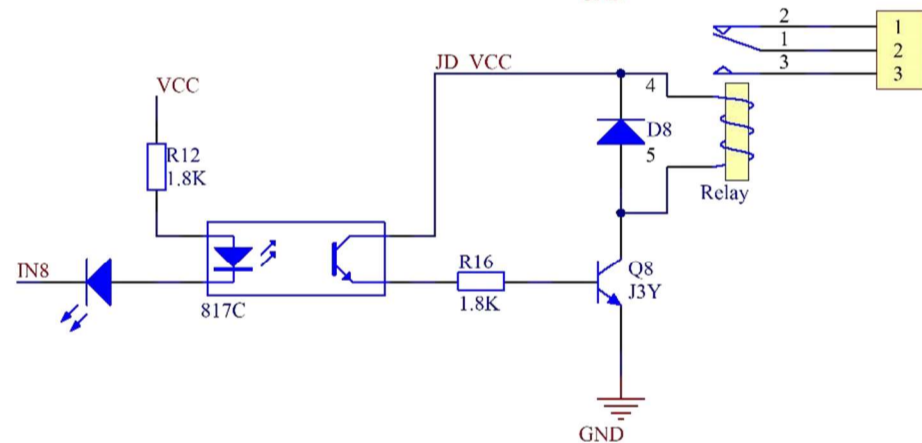
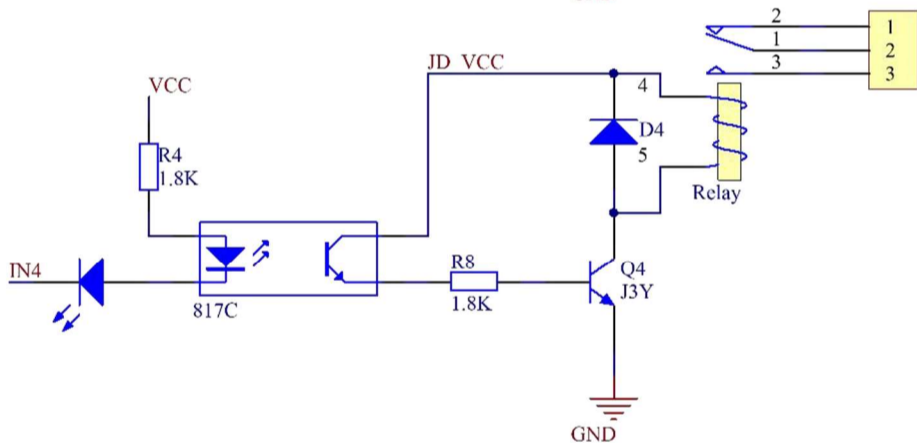

How the Relay Work?

As we may know, relay is a device which is used to provide connection between two or more points or devices in response to the input signal applied. In other words, relays provide isolation between the controller and the device as devices may work on AC as well as on DC. However, they receive signals from a micro-controller which works on DC hence requiring a relay to bridge the gap. Relay is extremely useful when you need to control a large amount of current or voltage with small electrical signal. There are 5 parts in every relay:

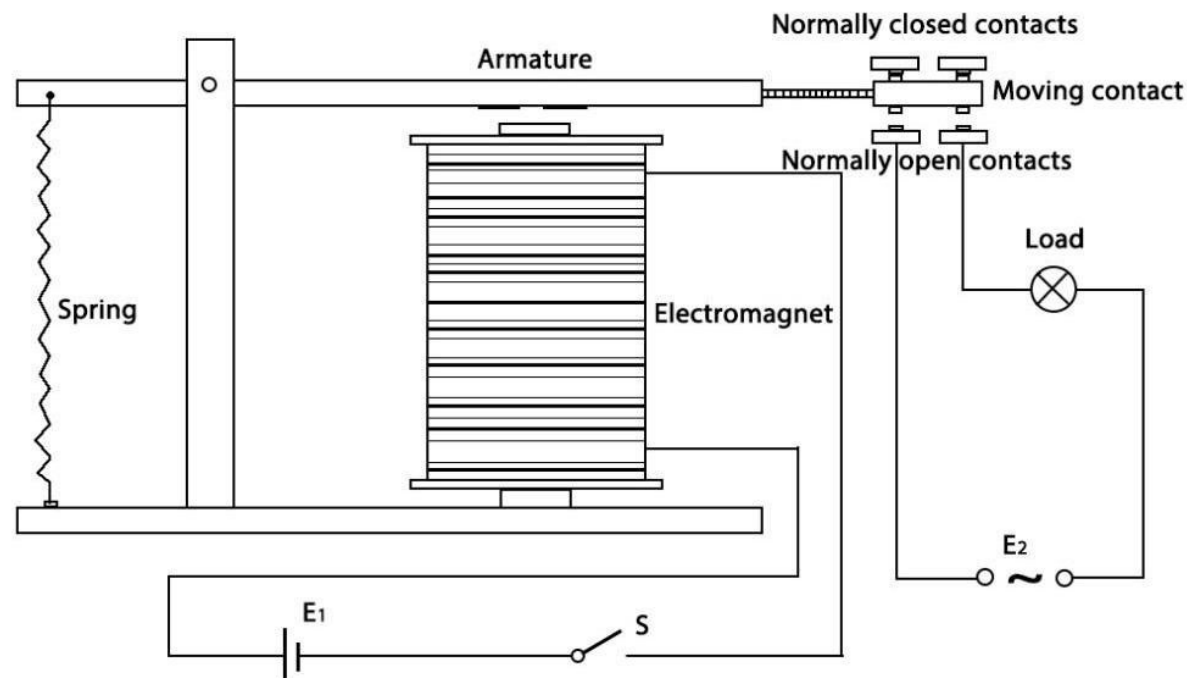

- **Electromagnet** - It consists of an iron core wound by coil of wires. When electricity is passed through, it becomes magnetic. Therefore, it is called electromagnet.

- **Armature** - The movable magnetic strip is known as armature. When current flows through them, the coil is energized thus producing a magnetic field which is used to make or break the normally open (N/O) or normally close (N/C) points. And the armature can be moved with direct current (DC) as well as alternating current (AC).
- **Spring** - When no currents flow through the coil on the electromagnet, the spring pulls the armature away so the circuit cannot be completed.

Set of electrical **contacts** - There are two contact points:

Normally open - connected when the relay is activated, and disconnected when it is inactive.

- **Normally close** - not connected when the relay is activated, and connected when it is inactive.
- **Molded frame** - Relays are covered with plastic for protection.

The working principle of relay is simple. When power is supplied to the relay, currents start flowing through the control coil; as a result, the electromagnet starts energizing. Then the armature is attracted to the coil, pulling down the moving contact together thus connecting with the normally open contacts. So the circuit with the load is energized. Then breaking the circuit would a similar case, as the moving contact will be pulled up to the normally closed contacts under the force of the spring. In this way, the switching on and off of the relay can control the state of a load circuit.

8ch Relay Module	Arduino Board
GND	GND
IN1	12
IN2	11
IN3	10

IN4	9
IN5	8
IN6	7
IN7	6
IN8	5
VCC	5V

How to Use in Arduino?

Build the Circuit

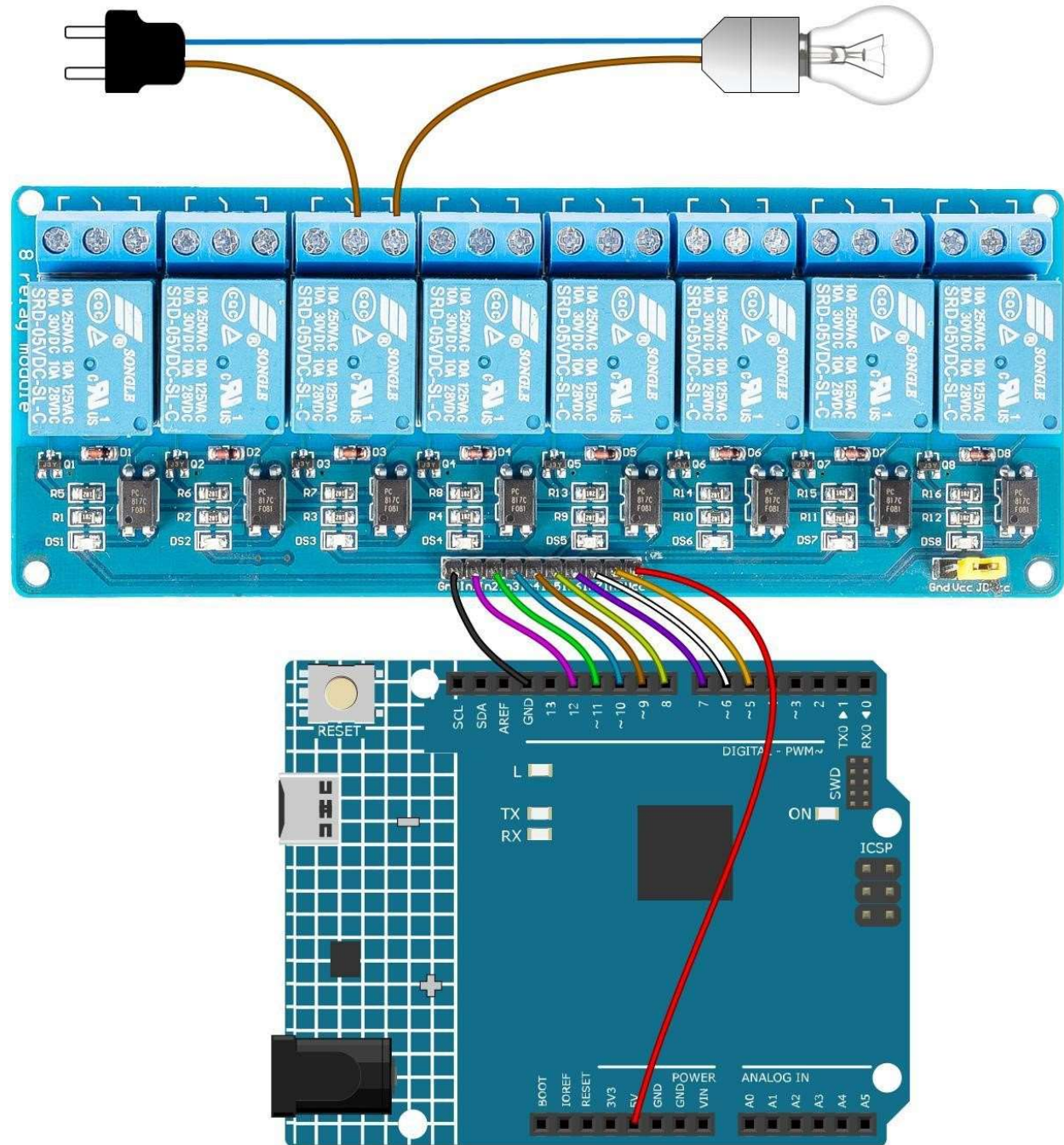

Copy and Upload the Code

1. Copy and paste the following code to the Arduino IDE.

```
// Define the pins where the relay modules are connected
const int relayPins[] = {12, 11, 10, 9, 8, 7, 6, 5};
const int numRelays = sizeof(relayPins) / sizeof(relayPins[0]); // Calculate the number of relays

void setup() {
  for (int i = 0; i < numRelays; i++) { pinMode(relayPins[i], OUTPUT); //
    Initialize each relay pin as an output
    digitalWrite(relayPins[i], HIGH); // Initially, all relays are turned off (HIGH for low-level trigger)
  }
}

void loop() {
  for (int i = 0; i < numRelays; i++) { digitalWrite(relayPins[i], LOW); // Activate
    current relay (LOW for low-level trigger) delay(1000); // Delay for 1 second
    digitalWrite(relayPins[i], HIGH); // Deactivate current relay
    delay(2000); // Short delay before activating the next relay
  }
}
```

2. Choose the board and port you use.



3. Click the **Upload** button.



4. Now you can see that relays are closing alternately, and you can hear the clicking sound as well as see the signal indicator lights lighting up one after the other. If you have connected a bulb as a load, you can also see the bulb lighting up.

How to Use in Raspberry Pi?



8ch Relay Module	Raspberry Pi
GND	GND
IN1	17
IN2	18
IN3	27
IN4	22
IN5	23
IN6	24
IN7	12
IN8	16
VCC	5V

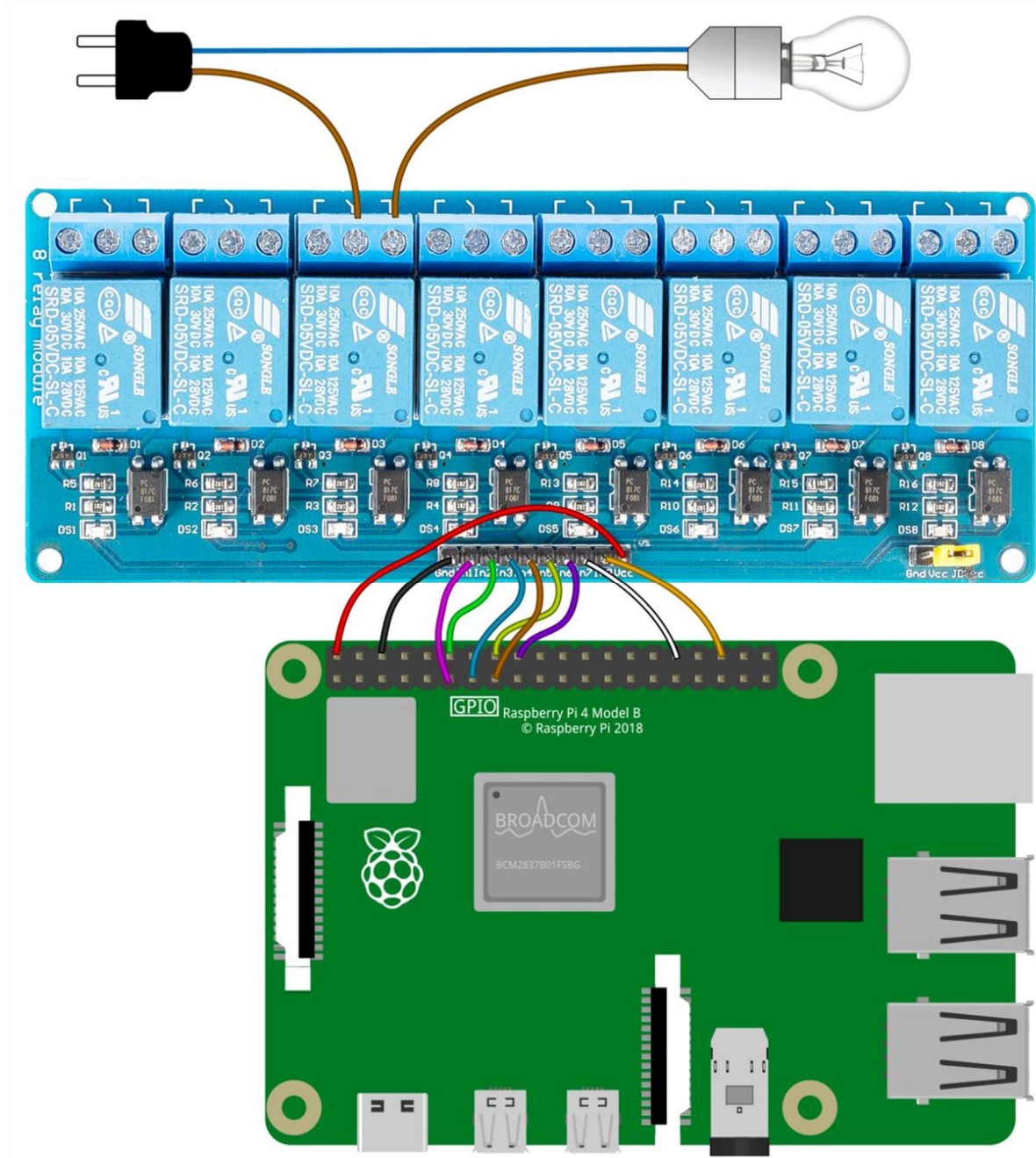

Build the Circuit

Download and Run the Code

Step 1: Download the code package.

```
wget http://wiki.sunfounder.cc/images/5/5f/8_channel_relay_low_rpi.zip
```

Step2: Unzip the file.

```
unzip 8_channel_relay_low_rpi.zip
```

Step3: Run the code.

```
sudo python3 8_channel_relay_low_rpi.py
```

Step4: Now you can see that relays are closing alternately, and you can hear the clicking sound as well as see the signal indicator lights lighting up one after the other. If you have connected a bulb as a load, you can also see the bulb lighting up.