

## General-purpose Relay **G2R- $\approx$ -S** (S)

### Slim and Space-saving Power Plug-in Relay

- Reduces wiring work by 60% when combined with the P2RF- $\approx$ -PU Push-In Plus Socket (according to actual OMRON measurements).
- Lockable test button models available.
- Built-in mechanical operation indicator.
- Provided with nameplate.
- AC type is equipped with a coil-disconnection self-diagnostic function (LED type).
- High switching power (1-pole: 10 A).

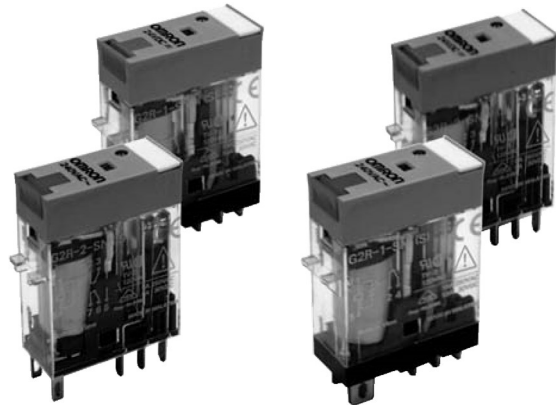

For the most recent information on models that have been certified for safety standards, refer to your OMRON website.

### Model Number Structure Model Number Legend

G2R -  $\frac{\quad}{1}$  -  $\frac{S}{2}$   $\frac{\square}{3}$   $\frac{\square}{4}$  (S)  $\frac{\square}{5}$

**1. Number of Poles**      **4. Rated Coil Voltage**

1:1 pole

2:2 poles

**2. Terminals**S: Plug-in

**3. Classification**

Blank: General-purpose

N: LED indicator

D: Diode

ND: LED indicator and diode

NI: LED indicator with test button

NDI: LED indicator and diode with test button

**5. Mechanical operation indicator and Nameplate**

(S): Models with mechanical operation indicator and Nameplate

**Note:** Contact your OMRON representative for Relays with gold-plated contacts.

### Ordering Information

When your order, specify the rated voltage.

## List of Models

Classification	Coil ratings	Contact form	
		SPDT	DPDT
General-purpose	AC 24, 48, 110, 120, 230, 240 DC 6, 12, 24, 48	G2R-1-S (S)	G2R-2-S (S)
LED indicator		G2R-1-SN (S)	G2R-2-SN (S)
LED indicator with test button		G2R-1-SNI (S)	G2R-2-SNI (S)
Diode	DC 6, 12, 24, 48	G2R-1-SD (S)	G2R-2-SD (S)
LED indicator and diode		G2R-1-SND (S)	G2R-2-SND (S)
LED indicator and diode with test button		G2R-1-SNDI (S)	G2R-2-SNDI (S)

**Note: 1.** The standard models are compliant with UL/CSA and VDE standards. Also, an EC compliance declaration has been made for combinations with the P2RF-≡-E, P2RF-≡-S and P2RF-≡-PU. The Relays bear the CE Marking.

**2.** Refer to *Connecting Sockets*, below, for applicable Socket models.

**3.** When ordering, add the rated coil voltage and "(S)" to the model number. Rated coil voltages are given in the coil ratings table.

Example: G2R-1-S 12 VDC (S)

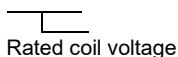

## Accessories (Order Separately)

### Connecting Sockets

#### Track/surface-mounting Socket

Applicable relay model*1	Mounting Method	Conductive part protection	Terminal Type	Applicable crimp terminal/ Electric wire	Exclusive short bar (Order Separately)	Appearance	Model
G2R-1-S	Mounted on a DIN track or with screws	Available	Push-In Plus Terminal	Ferrules Solid wire Stranded wire	Available		P2RF-05-PU *2
			Screw terminal (M3 screw size)	Forked terminals Solid wire Stranded wire	Available		P2RFZ-05-E *4
		Option (Terminal cover sold separately) *3	Screw terminal (M3.5 screw size)	Round terminals Forked terminals Solid wire Stranded wire	Available		P2RFZ-05
G2R-2-S	Mounted on a DIN track or with screws	Available	Push-In Plus Terminal	Ferrules Solid wire Stranded wire	Available		P2RF-08-PU *2
			Screw terminal (M3 screw size)	Forked terminals Solid wire Stranded wire	Available		P2RFZ-08-E *4
		Option (Terminal cover sold separately) *3	Screw terminal (M3.5 screw size)	Round terminals Forked terminals Solid wire Stranded wire	Available		P2RFZ-08

\*1.The applicable relay model is a plug-in terminal type.

\*2.There are screw mounting holes in the DIN hooks on the P2RF-≡-PU. Pull out the DIN hook tabs to mount the Sockets with screws.

\*3.Terminal cover type is P2CZ-Z. (Order Separately) For details, refer to the on page 5.

\*4.The finger-protection type (P2RFZ-≡-E) is a type in which the terminal cover is integrated into the socket. Round terminals cannot be used. Use forked terminals or ferrules instead.

#### Back-mounting Socket

Applicable Relay model	Mounting Method	Appearance	Models
------------------------	-----------------	------------	--------

G2R-1-S	PCB terminals		P2R-05P
			P2R-057P
	Solder terminals		P2R-05A
G2R-2-S	PCB terminals		P2R-08P
			P2R-087P
	Solder terminals		P2R-08A

### For Push-In Plus Terminal Block Sockets

#### Short Bars

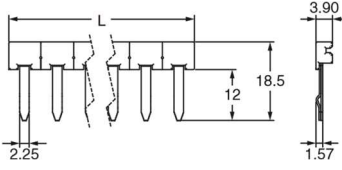
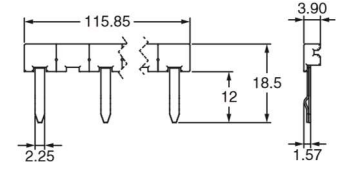
Applicable sockets	Pitch	Application	Shape/external dimensions	Number of poles	L (Length)	Insulation color	Short Bars Model*1	Maximum carry current
P2RF-05-PU P2RF-08-PU	7.75 mm	Bridging contact terminals (common)		2	15.1	Red (R) Blue (S) Yellow(Y)	PYDN-7.75-020≡	20 A
				3	22.85		PYDN-7.75-030≡	
				4	30.6		PYDN-7.75-040≡	
				20	154.6		PYDN-7.75-200≡	
	15.5 mm	For Coil terminals		8	115.55		ITΨΔN-15.5-080≡	

\*1. Replace the box (≡) in the model number with the code for the covering color. ≡Color selection: R = Red, S = Blue, Y = Yellow

#### Labels

Applicable sockets	Model	Manufacturer	Minimum order (Box) (quantity per Box)
P2RF-05-PU P2RF-08-PU	MG-CPM-04 41390N	Cembre	1,680 (35 Sheet/48 Pieces)

Note: PRINTER: MARKINGENIUS MG3 (Ask to your Omron contact for more details on printers)

### For Screw Terminal Sockets

#### Short Bars

Applicable sockets	Pitch	Appearance	Dimensions (mm)	Number of poles	Insulation color	Short Bars Model	Maximum carry current	Minimum order (set)
--------------------	-------	------------	-----------------	-----------------	------------------	------------------	-----------------------	---------------------

P2RFZ-08-E for shorting contact COM terminals	6.8 mm		20	Blue(S)	P2DN-6.8-100S	20 A	1
P2RFZ-05-E P2RFZ-08-E	15.7 mm		10		P2DN-15.7-100S		
P2RFZ-08 for shorting contact COM terminals	8.5 mm		20	Blue(S)	P2DN-8.5-100S	20 A	1
P2RFZ-05 P2RFZ-08	19.4 mm		10		P2DN-19.4-100S		

**Note:** 1. Select an applicable type of short bars by checking applicable socket type, appearance, and dimensions.

2. Use the Short Bars for crossover wiring within one Socket or between Sockets.

3. Use the short bars on the lower section of the socket.

When using the short bars on the upper section of the socket, insert them so that their heads are pointed upwards (see the figure below). Otherwise, short bars may interfere with the socket, leading to improper wiring and contact failure.

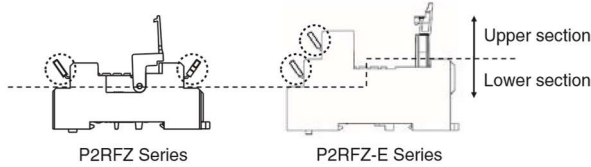

\* One set (order unit) contains 10 short bars and 20 caps.

## Accessories for Short Bars (P2DN)

### Cap

Short Bars Models	Appearance	Dimensions (mm)	Model
P2DN-8.5-100S P2DN-19.4-100S P2DN-6.8-100S P2DN-15.7-100S			P2DN-CP100

## For Screw Terminal Sockets (P2RFZ-05/P2RFZ-08)

### Terminal covers

Applicable sockets	Appearance	Model	Minimum order (set)
P2RFZ-05 P2RFZ-08		P2CZ-C	

**Note:** 1. Use these covers in a combination with P2RFZ-05 and P2RFZ-08.

2. Do not install short bars (optional) on the upper section (see the figure below).

Short bars may interfere with the terminal cover, making the terminal cover unusable.

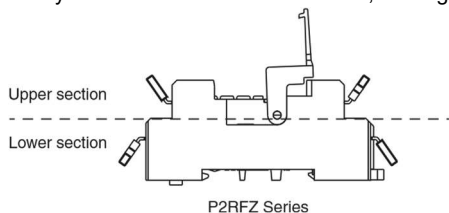

**Dimensions with terminal cover P2RFZ-05 P2RFZ-08**

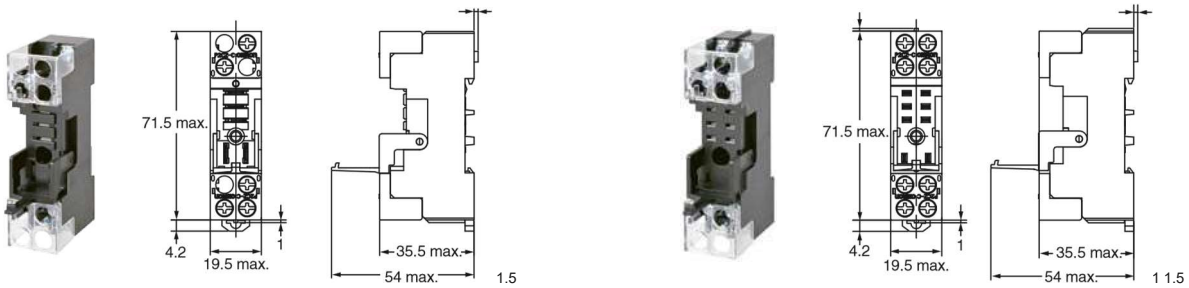

**Labels**

Applicable sockets	Model	Manufacturer	Minimum order (Box) (quantity per Box)
P2RFZ-≡-E	<b>MG-CPM-04 41390N</b>	Cembre	1680 (35 Sheet/48 Pieces)

**Note:** 1. PRINTER: MARKINGENIUS MG3 (Ask to your Omron contact for more details on printers)  
 2. This label cannot be applied on sockets other than P2RFZ-≡-E.

**Mounting Tracks**

Applicable Socket	Description	Model	Minimum order (quantity)
Track-connecting Socket	Mounting track	50 cm (l) × 7.3 mm (t): <b>PFP-50N</b>	---
		1 m (l) × 7.3 mm (t): <b>PFP-100N</b>	
		1 m (l) × 16 mm (t): <b>PFP-100N2</b>	
	End plate *1	<b>PFP-M</b>	10
	Spacer	<b>PFP-S</b>	
Back-connecting Socket	Mounting plate *2	<b>P2R-P</b>	1

\*1. When mounting DIN rail, please use End Plate (PFP-M). Use the Short Bars for crossover wiring within one Socket or between Sockets.  
 \*2. Used to mount several P2R-05A and P2R-08A Connecting Sockets side by side.

**Specifications**

**Coil Ratings**

Rated voltage	Rated current*		Coil resistance	Coil inductance (H) (ref. value)		Must operate voltage	Must release voltage	Max. voltage	Power consumption (approx.)	
	50 Hz	60 Hz		Armature OFF	Armature ON					
AC	24 V	43.5 mA	37.4 mA	253 Ω	0.81	1.55	80% max.	30% max.	110%	0.9 VA at 60 Hz
	48 V	21.8 mA	18.8 mA	1,040 Ω	3.12	6.17				
	110 V	9.5 mA	8.2 mA	5,566 Ω	13.33	26.83				
	120 V	8.6 mA	7.5 mA	7,286 Ω	16.13	32.46				
	230 V	4.4 mA	3.8 mA	27,172 Ω	72.68	143.90				
	240 V	4.2 mA	3.7 mA	27,800 Ω	90.58	182.34				
Rated voltage	Rated current*		Coil resistance	Coil inductance (H) (ref. value)		Must operate voltage	Must release voltage	Max. voltage	Power consumption (approx.)	
	50 Hz	60 Hz		Armature OFF	Armature ON					
DC	6 V	87.0 mA	69 Ω	0.25	0.48	70% max.	15% min.	110%	0.53 W	
	12 V	43.2 mA	278 Ω	0.98	2.35					
	24 V	21.6 mA	1,113 Ω	3.60	8.25					
	48 V	11.4 mA	4,220 Ω	15.2	29.82					

**Note:** 1. The rated current and coil resistance are measured at a coil temperature of 23°C with tolerances of +15%/-20% for the AC rated current and ±10% for the DC coil resistance.  
 2. The AC coil resistance and inductance values are reference values only (at 60 Hz).  
 3. Operating characteristics were measured at a coil temperature of 23°C.  
 4. The maximum voltage is the maximum possible value of the voltage that can be applied to the relay coil. It is not the maximum voltage that can be applied continuously.

## Contact Ratings

Number of poles	1 pole		2 poles	
Load	Resistive load ( $\cos\phi = 1$ )	Inductive load ( $\cos\phi = 0.4$ ; L/R = 7 ms)	Resistive load ( $\cos\phi = 1$ )	Inductive load ( $\cos\phi = 0.4$ ; L/R = 7 ms)
Rated load	10 A at 250 VAC; 10 A at 30 VDC	7.5 A at 250 VAC; 5 A at 30 VDC	5 A at 250 VAC; 5 A at 30 VDC	2 A at 250 VAC; 3 A at 30 VDC
Rated carry current	10 A		5 A	
Max. switching voltage	440 VAC, 125 VDC		380 VAC, 125 VDC	
Max. switching current	10 A		5 A	
Max. switching power	2,500 VA, 300 W	1,875 VA, 150 W	1,250 VA, 150 W	500 VA, 90 W
Failure rate (reference value) *	100 mA at 5 VDC		10 mA at 5 VDC	

Note: P level:  $\lambda_{60} = 0.1 \times 10^{-6}$ /operation

\*This value was measured at a switching frequency of 120 operations per minute.

## Characteristics

Item	1 pole	2 poles
Contact configuration	SPDT	
Contact structure	Single	
Contact resistance	100 m $\Omega$ max.	
Operate (set) time	15 ms max.	
Release (reset) time	AC: 10 ms max.; DC: 5 ms max. (w/built-in diode: 20 ms max.)	AC: 15 ms max.; DC: 10 ms max. (w/built-in diode: 20 ms max.)
Max. operating frequency	Mechanical: 18,000 operations/hr Electrical: 1,800 operations/hr (under rated load)	
Insulation resistance	1,000 M $\Omega$ min. (at 500 VDC)	
Dielectric strength *	5,000 VAC, 50/60 Hz for 1 min between coil and contacts; 1,000 VAC, 50/60 Hz for 1 min between contacts of same polarity	5,000 VAC, 50/60 Hz for 1 min between coil and contacts; 3,000 VAC, 50/60 Hz for 1 min between contacts of different polarity 1,000 VAC, 50/60 Hz for 1 min between contacts of same polarity
Vibration resistance	Destruction: 10 to 55 to 10 Hz, 0.75 mm single amplitude (1.5 mm double amplitude) Malfunction: 10 to 55 to 10 Hz, 0.75 mm single amplitude (1.5 mm double amplitude)	
Shock resistance	Destruction: 1,000 m/s <sup>2</sup> Malfunction: 200 m/s <sup>2</sup> when energized; 100 m/s <sup>2</sup> when not energized	
Endurance	Mechanical: AC coil: 10,000,000 operations min.; DC coil: 20,000,000 operations min. (at 18,000 operations/hr) Electrical: 100,000 operations min. (at 1,800 operations/hr under rated load)	
Ambient temperature	Operating: -40°C to 70°C (with no icing or condensation)	
Ambient humidity	Operating: 5% to 85%	
Weight	Approx. 20 g	

Note: Values in the above table are the initial values.

\*These values are relay only. Please refer to the "Products Related to Common Sockets and DIN Tracks Data Sheet" for connecting sockets.

## Approved Standards

### UL 508 (File No. E41643)

### IEC/VDE (Certificate No. 40015012 EN 61810-1)

Model	Contact form	Coil ratings	Contact ratings	Operations
G2R-1-S (S)	SPDT	5 to 110 VDC 6 to 240 VAC	10 A, 30 VDC (resistive) 10 A, 250 VAC (general use)	100 × 10 <sup>3</sup>
			TV-3 (NO contact only)	25 × 10 <sup>3</sup>
G2R-2-S (S)	DPDT	5 to 110 VDC 6 to 240 VAC	5 A, 30 VDC (resistive) 5 A, 250 VAC (general use)	100 × 10 <sup>3</sup>
			TV-3 (NO contact only)	25 × 10 <sup>3</sup>

Contact form	Coil ratings	Contact ratings	Operations
1 pole	6, 12, 24, 48 VDC 24, 110, 120, 230, 240 VAC	5 A, 440 VAC ( $\cos\phi = 1.0$ ) 10 A, 250 VAC ( $\cos\phi = 1.0$ ) 10 A, 30 VDC (0 ms)	100 × 10 <sup>3</sup>
2 poles	6, 12, 24, 48 VDC 24, 110, 120, 230, 240 VAC	5 A, 250 VAC ( $\cos\phi = 1.0$ ) 5 A, 30 VDC (0 ms)	100 × 10 <sup>3</sup>

LR

Model	Contact form	Coil ratings	Contact ratings	Operations
G2R-1-S (S)	SPDT	5 to 110 VDC 6 to 240 VAC	A, 30 VDC (resistive) A, 250 VAC (general use)	$\times 10^3$
			TV-3 (NO contact only)	$\times 10^3$
G2R-2-S (S)	DPDT		A, 30 VDC (resistive) A, 250 VAC (general use)	$\times 10^3$
			TV-3 (NO contact only)	$\times 10^3$

Number of poles	Coil ratings	Contact ratings	Operations
pole	5 to 110 VDC 6 to 240 VDC	A, 250 VAC (general use) A, 250 VAC (PF0.4) A, 30 VDC (resistive) 5A, 30VDC (L/R=7ms)	$\times 10^3$
poles	5 to 110 VDC 6 to 240 VDC	A, 250 VAC (general use) A, 250 VAC (PF0.4) A, 30 VDC (resistive) 3A, 30VDC (L/R=7ms)	$\times 10^3$

## Engineering Data

### Maximum Switching Power

G2R-1-S (S)

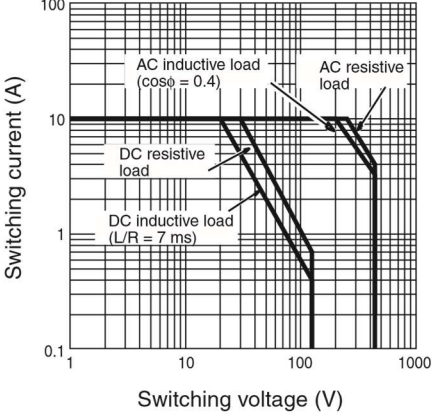

G2R-2-S (S)

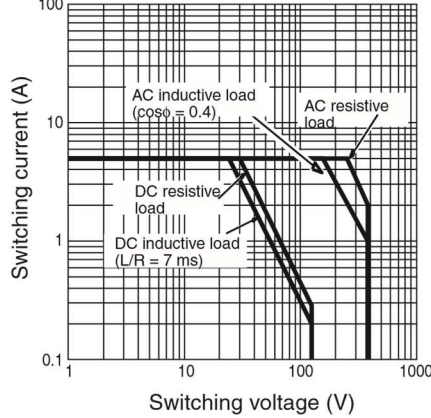

### Endurance

G2R-1-S (S)

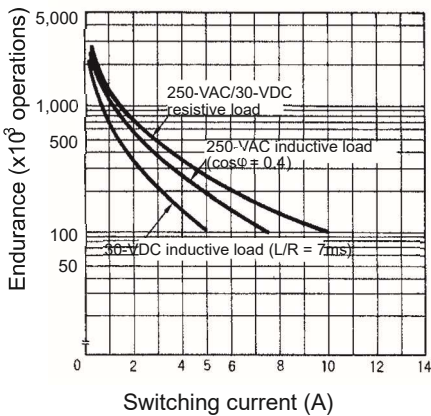

G2R-2-S (S)

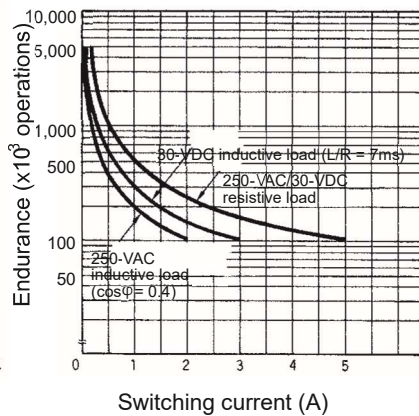

### Ambient Temperature vs Maximum Coil Voltage

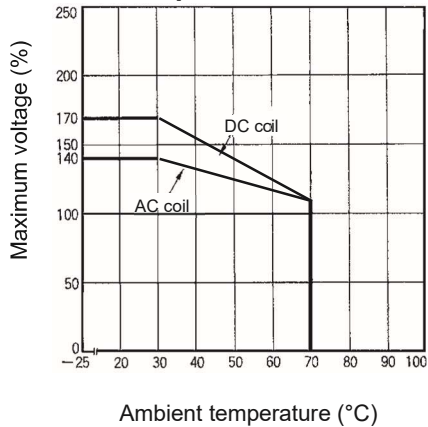

# Dimensions

(Unit: mm)

Note: All units are in millimeters unless otherwise indicated.

## SPDT Relays

G2R-1-S (S), G2R-1-SN (S), G2R-1-SNI (S)  
G2R-1-SD (S), G2R-1-SND (S), G2R-1-SNDI (S)

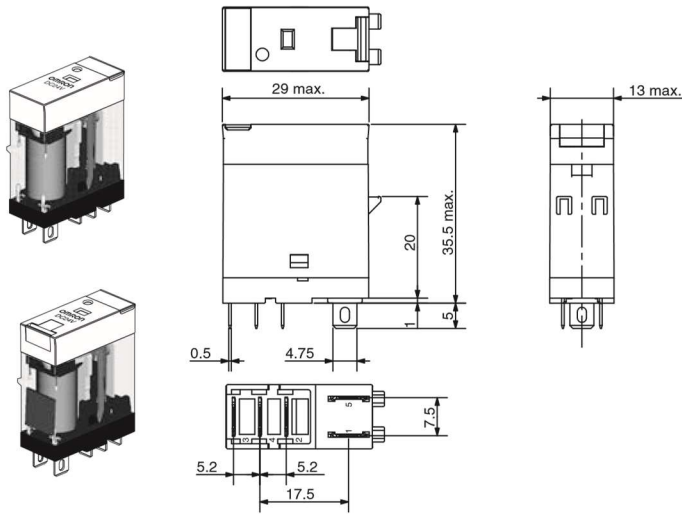

## Terminal Arrangement/Internal Connections (Bottom View)

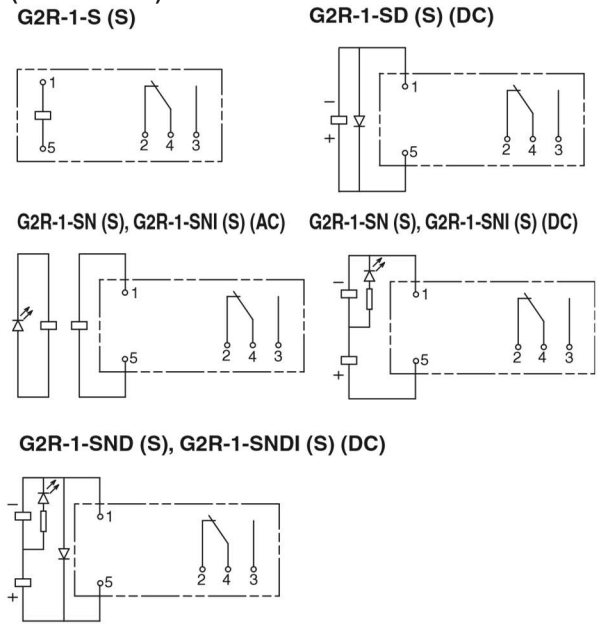

## DPDT Relays

G2R-2-S (S), G2R-2-SN (S), G2R-2-SNI (S)  
G2R-2-SD (S), G2R-2-SND (S), G2R-2-SNDI (S)

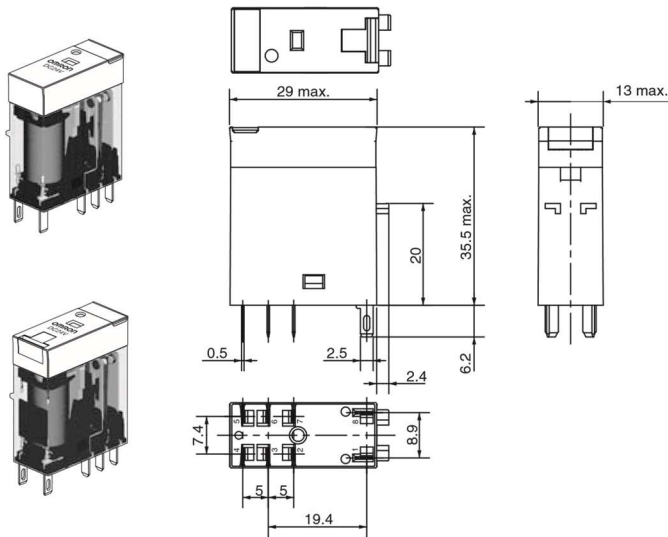

## Terminal Arrangement/Internal Connections (Bottom View)

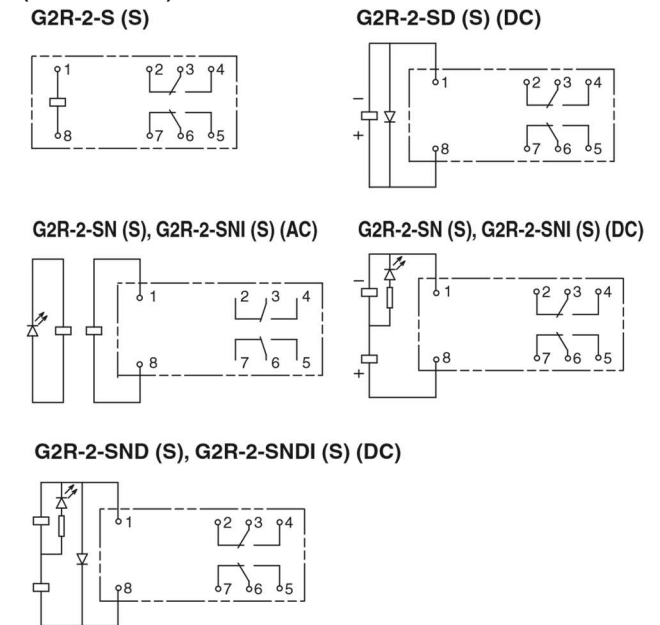

## Accessories (Order Separately)

### Socket Characteristics

Model	Rated carry current	Dielectric strength	Insulation resistance*	Remarks
P2RF-05-PU	10 A	Between contact terminals of same polarity: 1,000 VAC for 1 min	1,000 MΩ min.	
		Between coil and contact terminals: 4,000 VAC for 1 min		
P2RF-08-PU	6 A	Between contact terminals of different polarity: 3,000 VAC for 1 min	1,000 MΩ min.	
		Between contact terminals of same polarity: 1,000 VAC for 1 min		
		Between coil and contact terminals: 4,000 VAC for 1 min		
P2RFZ-05(-E)	10 A	Between contact terminals of same polarity: 1,000 VAC for 1 min	1,000 MΩ min.	
		Between coil and contact terminals: 4,000 VAC for 1 min		

P2RFZ-08(-E)	6 A	Between contact terminals of different polarity: 3,000 VAC for 1 min	1,000 MΩ min.
		Between contact terminals of same polarity: 1,000 VAC for 1 min	
		Between coil and contact terminals: 4,000 VAC for 1 min	
P2R-05P	10 A	Between contact terminals of same polarity: 1,000 VAC for 1 min	1,000 MΩ min.
		Between coil and contact terminals: 4,000 VAC for 1 min	
P2R-08P	5 A	Between contact terminals of different polarity: 3,000 VAC for 1 min	1,000 MΩ min.
		Between contact terminals of same polarity: 1,000 VAC for 1 min	
		Between coil and contact terminals: 4,000 VAC for 1 min	
P2R-057P	10 A	Between contact terminals of same polarity: 1,000 VAC for 1 min	1,000 MΩ min.
		Between coil and contact terminals: 5,000 VAC for 1 min	
P2R-087P	5 A	Between contact terminals of different polarity: 3,000 VAC for 1 min	1,000 MΩ min.
		Between contact terminals of same polarity: 1,000 VAC for 1 min	
		Between coil and contact terminals: 5,000 VAC for 1 min	
P2R-05A	10 A	Between contact terminals of same polarity: 1,000 VAC for 1 min	1,000 MΩ min.
		Between ground terminals: 1,500 VAC for 1 min	
		Between coil and contact terminals: 4,000 VAC for 1 min	
P2R-08A	5 A	Between contact terminals of different polarity: 3,000 VAC for 1 min	1,000 MΩ min.
		Between contact terminals of same polarity: 1,000 VAC for 1 min	
		Between ground terminals: 1,500 VAC for 1 min	
		Between coil and contact terminals: 4,000 VAC for 1 min	

\* The insulation resistance was measured with a 500-VDC insulation resistance meter at the same places as those used for measuring the dielectric strength.

## P2RF-05-PU

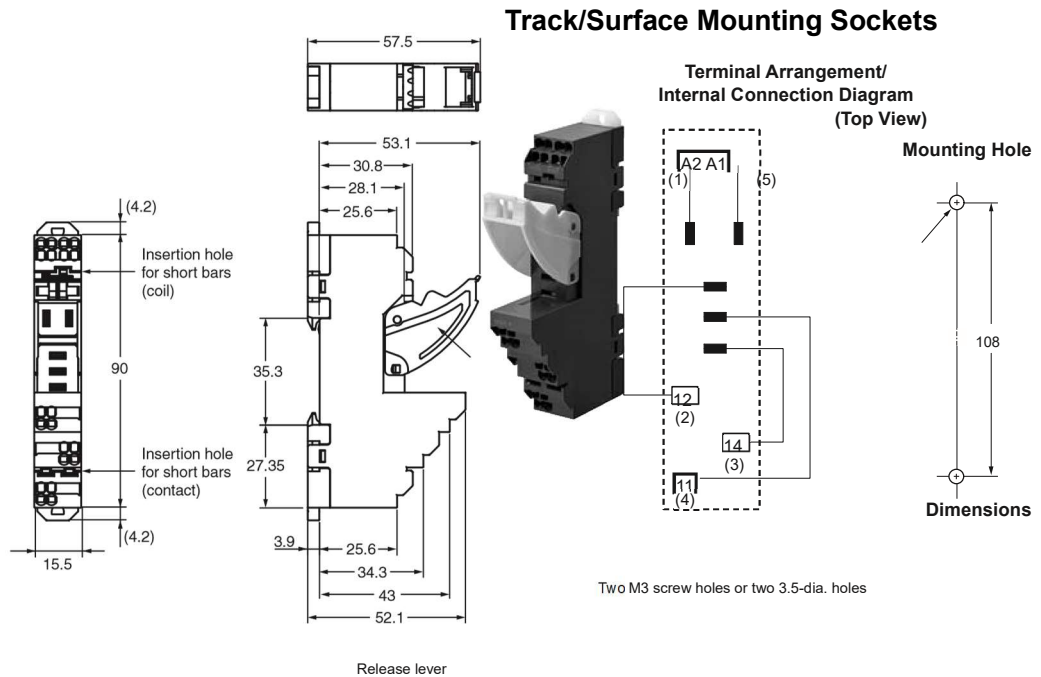

**Note: 1.** The numbers in parentheses are **Note:** Pull out the traditionally used terminal numbers. hooks to mount

**2.** Insert the short bar into only the the Socket with

A1 or A2 side.

screws.

**3.** Contact terminal crossover will result in functionality only on the No. 11 terminal side. The insertion hole on the No. 14 terminal side is a dummy hole for installing a short

**P2RF-08-PU**

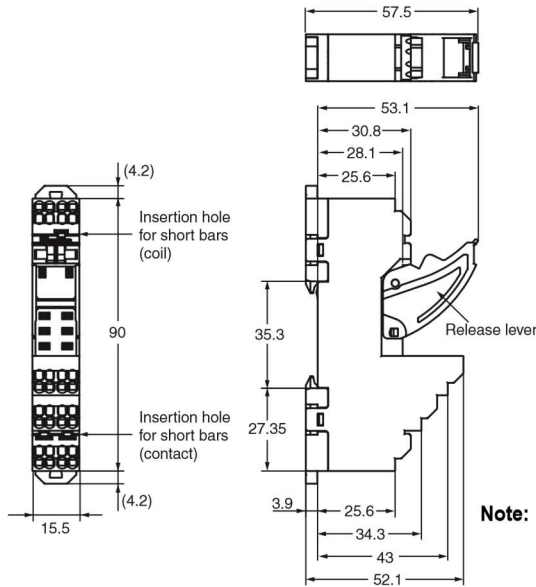

**Terminal Arrangement/  
Internal Connection Diagram  
(Top View)**

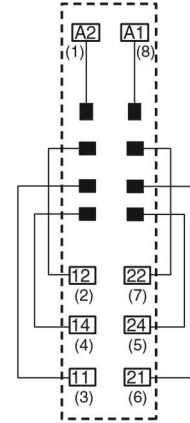

**Mounting Hole  
Dimensions**

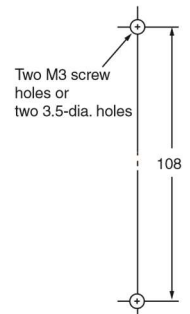

- Note:** 1. The numbers in parentheses are traditionally used terminal numbers.  
2. Insert the short bar into only the A1 or A2 side.

**Note:** Pull out the hooks to mount the Socket with screws.

**Accessories for P2RF-PU Short Bars**

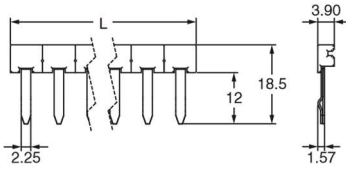

**PYDN-7.75-≡ (7.75 mm)**

Application	Pitch	No. of poles	(Length)	Colors	Model *	Maximum carry current
For Contact terminals (common)	7.75 mm	2	15.1	Red (R) Blue (S) Yellow (Y)	PYDN-7.75-020≡	A
		3	22.85		PYDN-7.75-030≡	
		4	30.6		PYDN-7.75-040≡	
		20	154.6		PYDN-7.75-200≡	
For Coil terminals	15.5 mm	8	115.85		PYDN-15.5-080≡	

\*Replace the box (≡) in the model number with the code for the covering color.

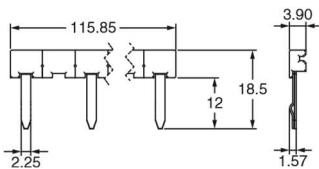

**PYDN-15.5-080≡ (15.5 mm)** **Note:** 1. Use the Short Bars for crossover wiring within one Socket or between Sockets. 2. When using short bar to coil terminals of PYF-≡-PU, make sure to use PYDN-31.0-080≡ (31 mm).

When using short bar to coil terminals of P2RF-≡-PU, make sure to use PYDN-15.5-080≡ (15.5 mm).

### P2RFZ-05-E (1-pole)

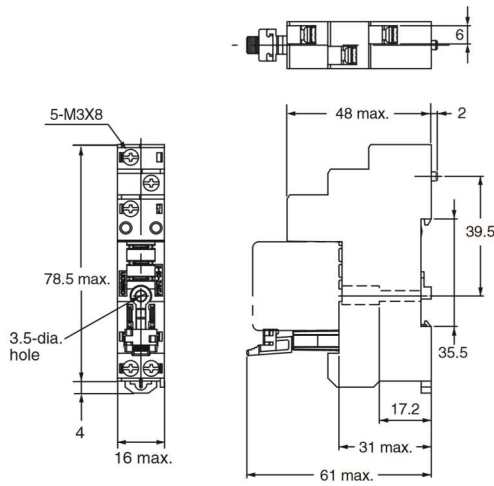

#### Terminal Arrangement/ Internal Connection Diagram (Top View)

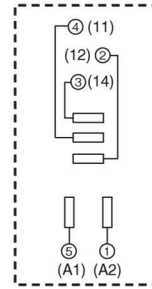

#### Mounting Hole

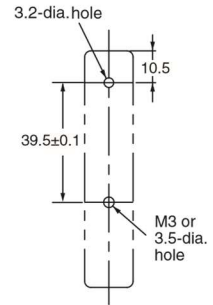

Note: Figures in parentheses indicate DIN standard numbers.

### P2RFZ-08-E (2-pole)

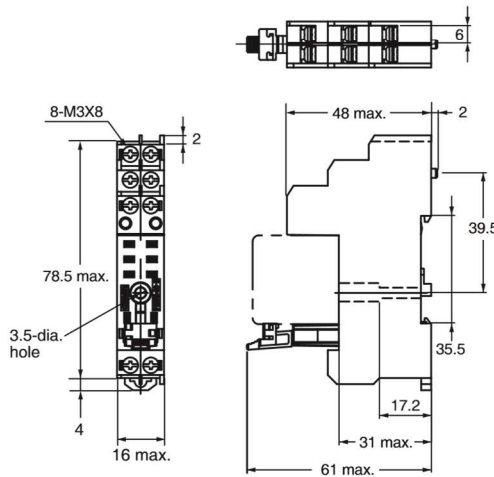

#### Terminal Arrangement/ Internal Connection Diagram (Top View)

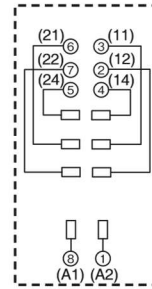

#### Mounting Hole Dimensions

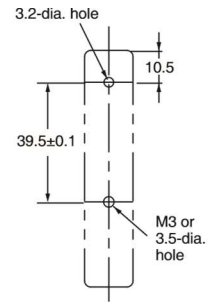

Note: Figures in parentheses indicate DIN standard numbers.

### P2RFZ-05

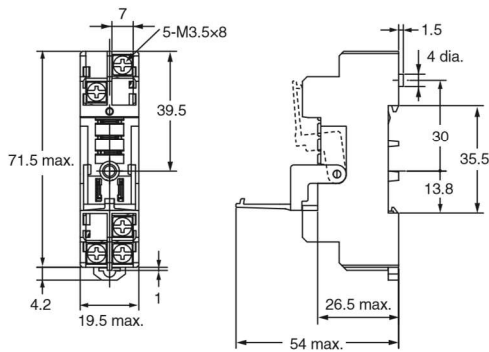

#### Terminal Arrangement/ Internal Connection Diagram (Top View)

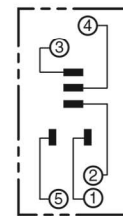

#### Mounting Hole Dimensions

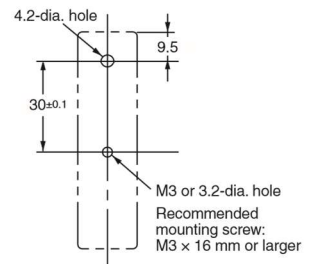

### P2RFZ-08

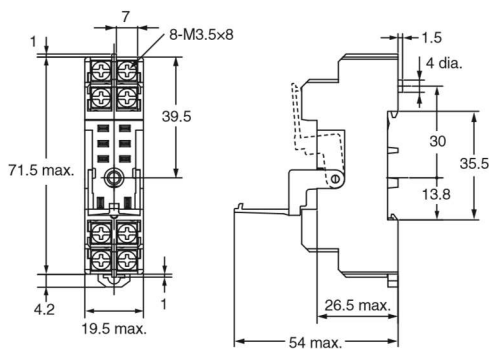

#### Terminal Arrangement/ Internal Connection Diagram (Top View)

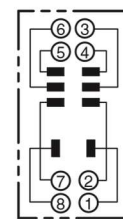

#### Mounting Hole Dimensions

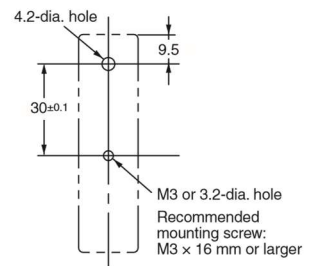

Dimensions

# Mounting Height of Relay with Track/Surface Mounting Sockets

## P2RF-05-PU

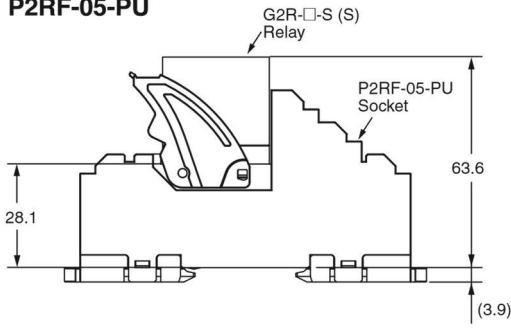

## P2RF-08-PU

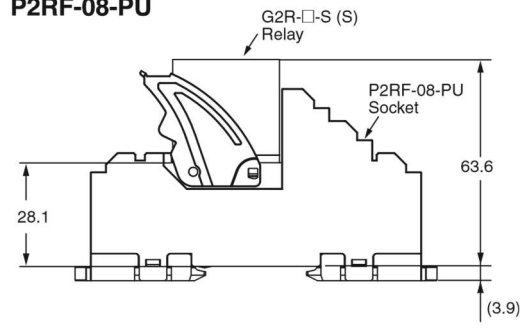

## P2RFZ-05

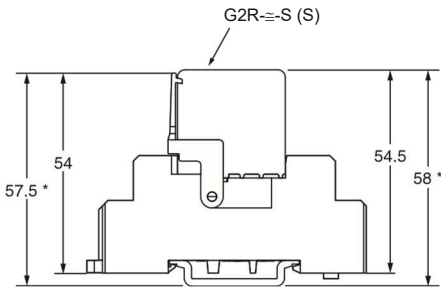

## P2RFZ-08

Heights become higher by approximately 9 mm when using PFP-≡N2.

\*These are values when using the DIN track PFP-≡N.

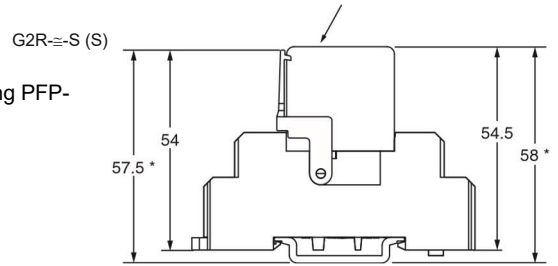

# Back-connecting Sockets

## P2R-05P (1-pole)

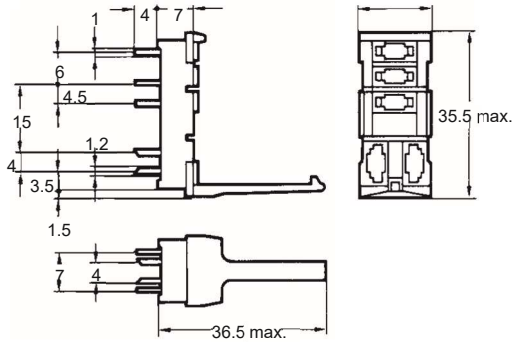
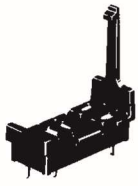

### Terminal Arrangement (Bottom View)



### Mounting Holes (Bottom View)

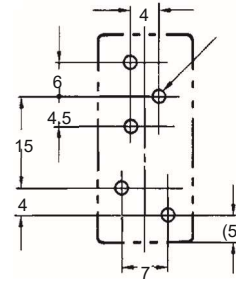

**P2R-08P (2-pole)**

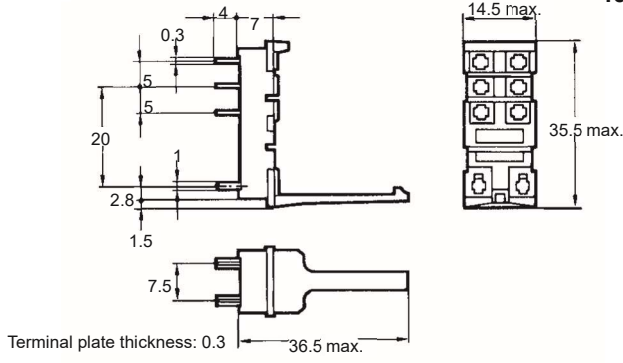
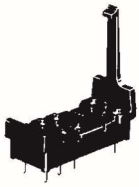

**Terminal Arrangement**

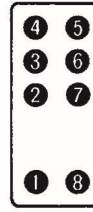

**Mounting Holes (Bottom View)**

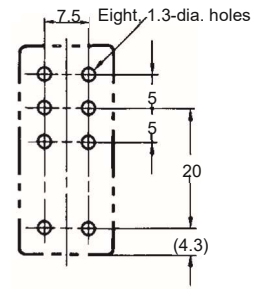

**P2R-05A (1-pole)**

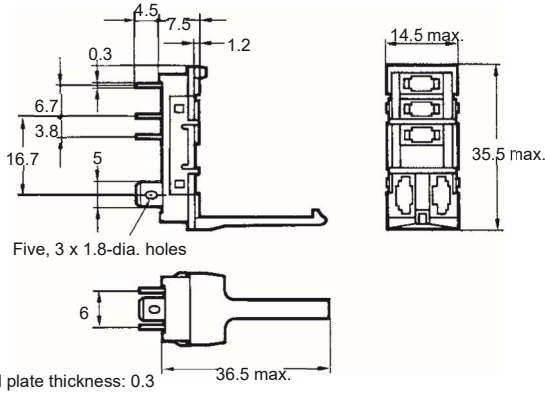
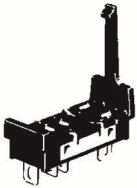

**Terminal Arrangement (Bottom View)**

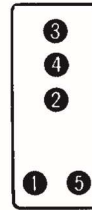

**Panel Cutout (Bottom View)**

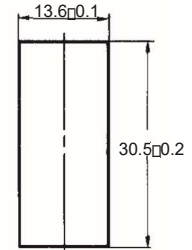

**P2R-08A (2-pole)**

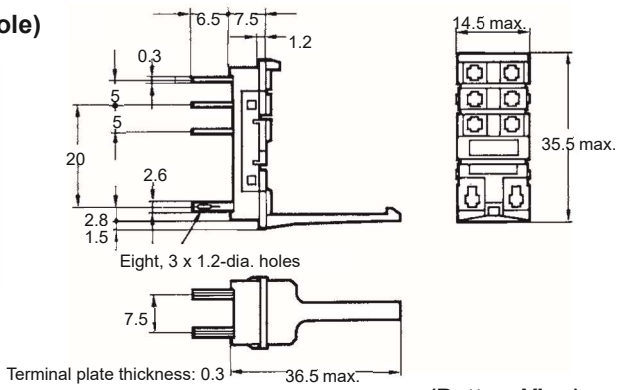
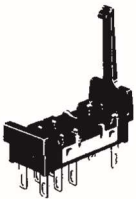

Recommended thickness of the panel is 1.6 to 2.0 mm

**(Bottom View)**

### P2R-057P (1-pole)

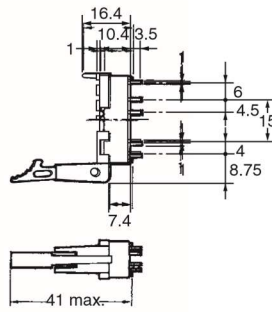
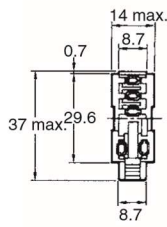
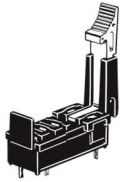

### Terminal Arrangement (Bottom View)

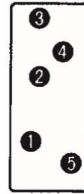

### Mounting Holes (Bottom View)

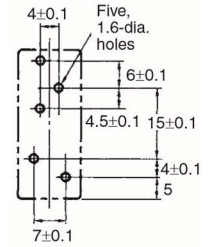

### P2R-087P (2-pole)

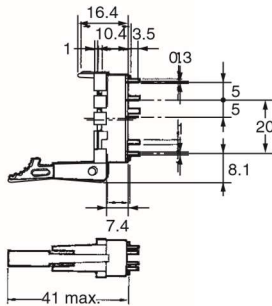
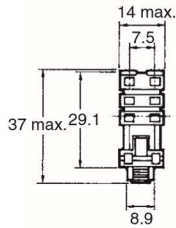
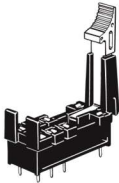

### Terminal Arrangement (Bottom View)



### Mounting Holes (Bottom View)

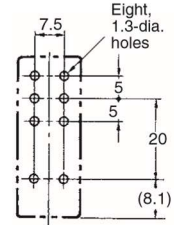

## Mounting Height of Relay with Back-connecting Sockets

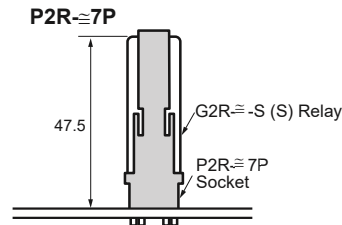
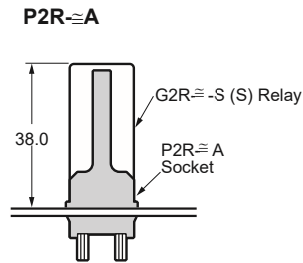
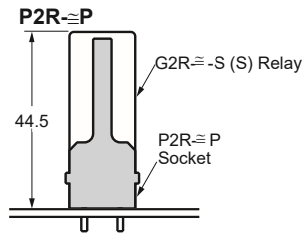

## Mounting Tracks

PFP-100N, PFP-50N

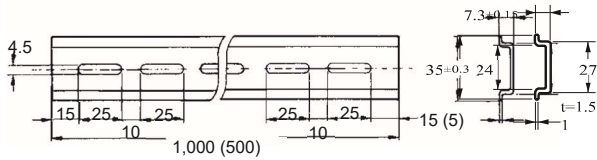
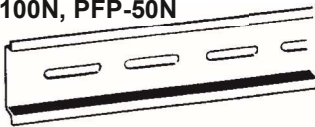

PFP-100N2

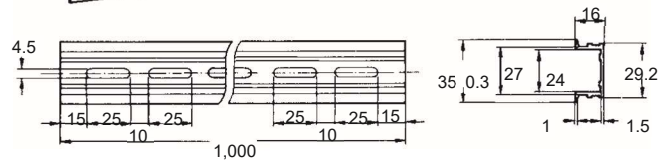

It is recommended to use a panel 1.6 to 2.0 mm thick.

## End Plate

PFP-M

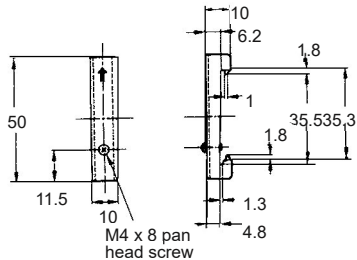
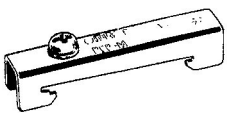

## Spacer

PFP-S

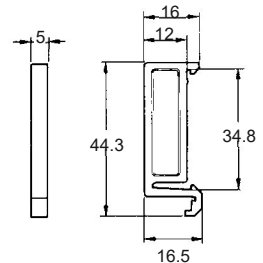
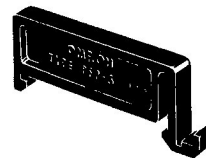

## Mounting Plate

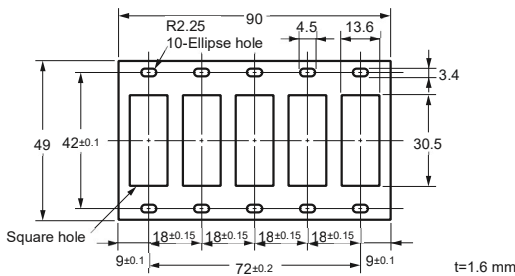



## Safety Precautions

Be sure to read the *Common Precautions for All Relay* in the website at the following URL: <http://www.ia.omron.com/>. Refer to *Products Related to Common Sockets and DIN Tracks* for precautions on the applicable Sockets.

Refer to *PYF-PU/P2RF-PU* for precautions on Push-In Plus Terminal Block Sockets.

### Warning Indications

 <b>CAUTION</b>	Indicates a potentially hazardous situation which, if not avoided, may result in minor or moderate injury or in property damage.
<b>Precautions for Correct Use</b>	Supplementary comments on what to do or avoid doing to prevent failure to operate, malfunction, or undesirable effects on product performance.
 <b>Cation</b>	

- Do not use the test button for any purpose other than testing. Be sure not to touch the test button accidentally as this will turn the contacts ON. Before using the test button, confirm that circuits, the load, and any other connected item will operate safely.
- Check that the test button is released before turning ON relay circuits.
- If the test button is pulled out too forcefully, it may bypass the momentary testing position and go straight into the locked position.
- Use an insulated tool when you operate the test button.

### Precautions for Correct Use

#### About the Built-in Diodes

The diodes that are built into the Relays are designed to absorb reverse voltage from the Relay's coil. If a large surge in voltage is applied to the diode from an external source, the element will be destroyed.

If there is the possibility of large voltage surges that could be applied to the elements from an external source, take any necessary surge absorption measures.

#### Latching Levers

- Turn OFF the power supply when operating the latching lever. After you use the latching lever always return it to its original state.
- Do not use the latching lever as a switch.
- The latching lever can be used for 100 operations minimum.

#### Relay Replacement

To replace the Relay, turn OFF the power supply to the load and Relay coil sides to prevent unintended operation and possible electrical shock.

#### Coil tape color

Pink tape is used for the AC coil type and blue tape is used for the DC coil type, making it easy to distinguish AC and DC.

#### Screw terminal socket

- Use the following tightening torque for screws during wiring.

Model	Tightening torque
P2RFZ-05-E P2RFZ-08-E P2RF-05-E P2RF-08-E	0.59 to 0.88 N·m *Use a No. 1 screwdriver.

- Use the following wire diameters as a guide for wiring.

(Select the appropriate wire diameter for the current used.)

Model	Recommended wire diameter (mm <sup>2</sup> )	
P2RFZ-05-E P2RFZ-08-E	Stranded wire	0.75 to 2.5 mm <sup>2</sup> AWG 18 to 14
P2RF-05-E P2RF-08-E	Solid wire	0.75 to 1.5 mm <sup>2</sup> AWG 18 to 16

### Using a short-circuit bar

- Use the short-circuit bar that is suitable for the socket you are using and the location of use.
- Note that the pitch of the short-circuit bar differs between the P2RFZ and P2RFZ-E.
- The short-circuit bar can be cut to match any number of poles. Cut with a tool as appropriate for the number of relays and sockets. When using a cut short-circuit bar, take care to avoid injuring yourself on the cut surface.
- When cutting with a tool, insert the tool from the plastic part and cut along the slot in the plastic part between terminals. If you cut a part other than the slot in the plastic part between terminals, it may not be possible to attach the insulating cap.

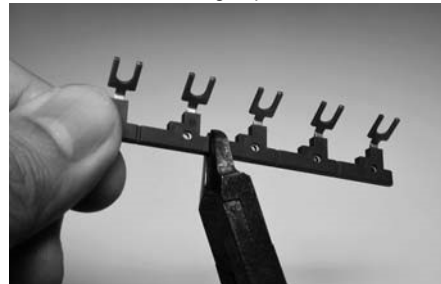

- When using a cut short-circuit bar (P2DN), always use the provided cap to protect the charger part.



- Use the short-circuit bar to short-circuit two or more coil terminals, or two or more contact COM terminals.
- Do not use a deformed short-circuit bar. Risk of failure, malfunctioning, or deterioration of characteristics.
- In socket terminals, insert the short-circuit bar in the correct orientation all the way into all terminals, and then secure with screws.
- Install the short-circuit bar before wiring.

### Common connection method when using a short bar

- When connecting the P2RF-PU input common, insert the short bar into only the A1 or A2 side.

### Equivalent Labels from Other Companies and Recommended Label Printers

Use the following label printer.

The following table gives the manufacturer's model number as of March 2017.

Manufacturer	Omron	Phoenix Contact	Weidmuller	Cembre
Label	XW5Z-P4.0LB1	UCT-TM6	MF 10/6	MG-CPM-04 41391
	XW5Z-P2.5LB2	UCT-TMF5	---	---

Label printer	--- *	BLUEMARK CLED, THERMOMA RK CARD SET PLUS, THERMOMA RK CARD	PrintJet ADVANCED, Plotter MCP Plus, Plotter MCP Basic	Markingenius MG3
---------------	-------	--	---	---------------------

\* When using a printing tool, use a Phoenix Contact label printer.

**Note:** Ask the label manufacturer or printer manufacturer for details.