

USB to serial chip CH340

1 Introduction

CH340 is a USB bus conversion chip, it can realize USB to UART interface or USB to printer interface.

In serial UART mode, CH340 provides common MODEM liaison signal, used to expand UART interface of computer or upgrade the common serial device to USB bus directly. For more information on USB conversion to printer interface please refer to the manual CH340DS2.

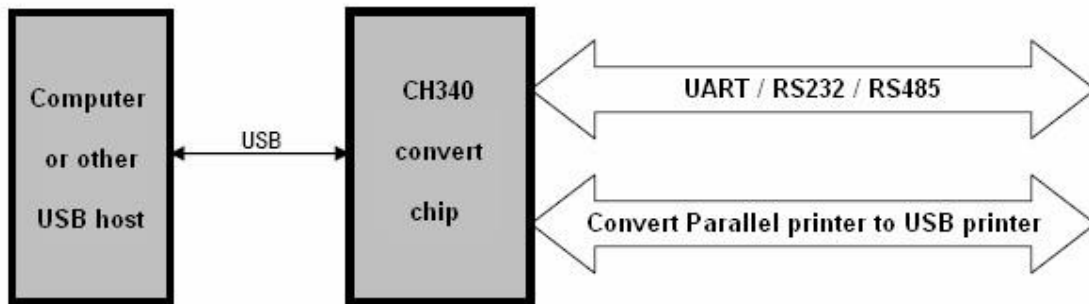

2 Features

- Full speed USB device interface, compatible with USB V2.0.
 - Emulate standard UART interface, used to upgrade the serial peripherals, or expand UART interface via USB bus.
 - Original serial applications are totally compatible, without any modification in Windows operation system.
 - Hardware full duplex serial UART interface, built-in transmit-receive buffer, supports communication baud rate varies from 50bps to 2Mbps.
 - Supports common MODEM liaison signal RTS, DTR, DCD, RI, DSR and CTS.
 - Through external level conversion chip provide further RS232, RS485, RS422 interface, etc.
 - CH340R supports IrDA criterion SIR infrared communication, supports baud rate varies from 2400bps to 115200bps.
 - Software compatible with CH341, use driver of CH341 directly.
 - Support 5V and 3.3V power supply even 3V.
 - CH340C, CH340E and CH340B have built-in crystal, no external crystal, CH340B also integrates EEPROM used to configure the serial number, etc.
 - SOP-16 and SSOP-20 and MSOP-10 lead-free RoHS compliant package.
-

3 Package

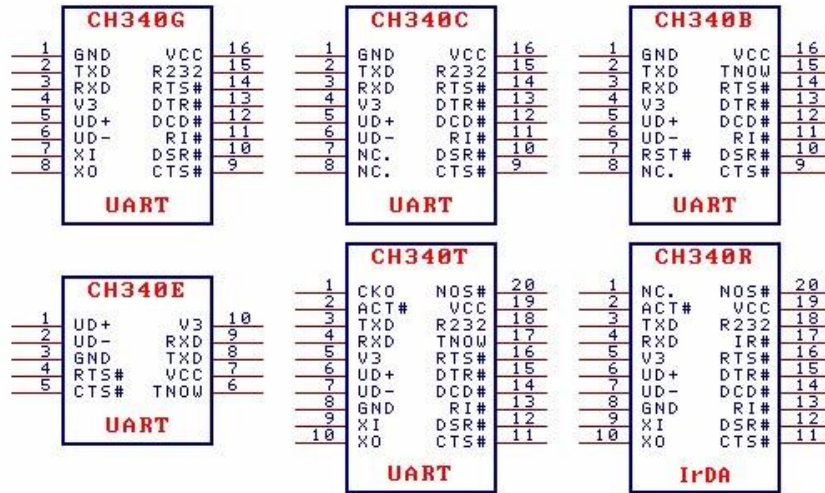

Package shape	Width of plastic		Pitch of Pin		Instruction of package	Ordering type
SOP-16	3.9mm	150mil	1.27mm	50mil	Small outline package of 16-pin	CH340G
SOP-16	3.9mm	150mil	1.27mm	50mil	Small outline package of 16-pin	CH340C
SOP-16	3.9mm	150mil	1.27mm	50mil	Small outline package of 16-pin	CH340B
MSOP-10	3.0mm	118mil	0.50mm	19.7mil	Shrink small outline package of 10-pin	CH340E
SSOP-20	5.30mm	209mil	0.65mm	25mil	Shrink small outline package of 20-pin	CH340T
SSOP-20	5.30mm	209mil	0.65mm	25mil	Shrink small outline package of 20-pin	CH340R

Model differences:

CH340C, CH340E and CH340B have built-in crystal, no external crystal;

CH340B also has built-in EEPROM used to configure the serial number, etc. Some functions can be customized.

CH340R provides reverse polarity TXD and MODEM signals. (No spot)

4. Pins

SSOP20 Pin No.	SOP16 Pin No.	MSOP10 Pin No.	Pin Name	Pin Type	Pin Description (description in bracket is only about CH340R)
19	16	7	VCC	POWER	Positive power input port, requires an external 0.1uF power decoupling capacitor
8	1	3	GND	POWER	Public ground, ground connection for USB
5	4	NONE	V3	POWER	Connect to VCC to input external power when 3.3V power supply, connect to 0.1uF decoupling capacitor when 5V

					power supply
9	7	NONE	XI	IN	CH340T/R/G: Input of crystal oscillator, connect to crystal and capacitor
			NC.	NONE	CH340C: No Connection, must be suspended
			RST#	IN	CH340B: Input of external reset, active low, built-in

3

					pull-up resistor
10	8	NONE	XO	OUT	CH340T/R/G: Output of crystal oscillator, connect to crystal and capacitor
			NC.	NONE	CH340C/B: No Connection, must be suspended
6	5	1	UD+	USB signal	Directly connect to D+ data wire of USB bus
7	6	2	UD-	USB signal	Directly connect to D- data wire of USB bus
20	NONE	NONE	NOS#	IN	Forbid USB device suspending, active low, built-in pull-up resistor
3	2	8	TXD	OUT	Transmit asynchronous data output(reverse output for CH340R)
4	3	9	RXD	IN	Receive asynchronous data input, built-in configurable pull-up and pull-down resistor
11	9	5	CTS#	IN	MODEM liaison input signal, clear to send, active low(high)
12	10	NONE	DSR#	IN	MODEM liaison input signal, data set ready, active low(high)
13	11	NONE	RI#	IN	MODEM liaison input signal, ring indicator , active low(high)
14	12	NONE	DCD#	IN	MODEM liaison input signal, data carrier detect, active low(high)
15	13	NONE	DTR#	OUT	MODEM liaison output signal, data terminal ready, active low(high)
16	14	4	RTS#	OUT	MODEM liaison output signal, request to send, active low(high)
2	NONE	NONE	ACT#	OUT	USB configuration completed state output, active low
18	15	NONE	R232	IN	CH340T/R/G/C: Assistant RS232 enable, active high, built-in pull-down resistor
17	15	6	TNOW	OUT	CH340T/E/B: Ongoing data transmission status indicator, active high
			IR#	IN	CH340R:Serial mode input setting, built-in pull-up resistor, SIR infrared serial interface when low, common serial interface when high

1	NONE	NONE	CK0	OUT	CH340T: clock output
			NC.	NONE	CH340R:No Connection, must be suspend

5. Function Description

CH340 chip has built-in USB pull-up resistor, UD+ and UD- pins must be connected to USB bus directly.

CH340 chip has built-in power-on reset circuit. CH340B also provides low active external reset pin.

CH340G/CH340T/CH340R chips need to work with 12MHz clock signal supplied to XI pin. Generally, clock signal is generated crystal oscillation with inverter in CH340. The peripheral circuit needs to place a crystal of 12MHz between XI and XO, and connect to a capacitor to ground separately.

CH340C, CH340E and CH340B chip have built-in clock generator, no external crystal and oscillating capacitor required.

CH340B chip also provides EEPROM for configuring data area, product serial number and other information could be customized for each chip by specific software tools, configurable data area is shown in the table below.

Byte Address	Abbreviation	Description of chip configuration data area	Default
00H	SIG	For CH340B: Internal configuration information valid reg, must be 58H. For CH340H/S: External configuration information valid reg, must be 53H. Invalid for other value	00H
01H	MODE	Serial mode, must be 23H	23H
02H	CFG	Specific configuration of chip, bit5 is used to configure product Serial Number: 0= valid; 1= invalid.	FEH
03H	WP	Internal configuration information write protect flag, 57H imply read only, otherwise can be rewrite	00H
05~04H	VID	Vendor ID, high byte is behind, any value. Set to 0000H or 0FFFFH implies VID and PID using vendor default value	1A86H
07~06H	PID	Product ID, high byte is behind, any value	7523H
0AH	PWR	Max Power, The maximum supply current in 2mA units	31H
17~10H	SN	Serial Number, the length of ASCII string is 8, disable the Serial number when the first byte is not ASCII character (21H~7FH)	12345678
3FH~1AH	PROD	For CH340B: Product String, Unicode string for Product description. The first byte is by total bytes (less than 26H), the next byte is 03H, Unicode string after that, using vendor default description when do not meet characteristics above.	Using product default description when the first byte is 00H

Others		(Reserved unit)	00H or FFH
--------	--	-----------------	------------

CH340 chip supports 5V and 3.3V power voltage. When using 5V source power, the VCC pin input 5V power and the V3 pin should connect with decoupling 0.1uF capacitor. When using 3.3V power voltage, connects V3 with VCC, both input 3.3V power voltage, and the other circuit voltage which connected with CH340 cannot exceed 3.3V.

CH340 supports USB device suspending automatically to save power. USB device suspend is forbidden when NOS# is driven low.

The DTR# pin of CH340 is used as a configuration input pin before the USB configuration is complete. An external 4.7KΩ pull-down resistor can be connected with this pin to generate default low level during USB enumeration, apply larger supply current to the USB bus via the configuration descriptor.

In UART mode, CH340 chip contains these pins: data transfer pins, MODEM liaison signal pins and assistant pins.

Data transfer pins contain: TXD and RXD pin. RXD keeps high when UART reception is idle. For CH340G/C/T/R chip, If R232 pin is driven high, assistant RS232 function will be enabled, an internal inverter will automatically insert to the RXD pin, and the pin becomes low by default. When UART transmission is idle, the TXD pin of CH340G/C/B/T keeps high, while CH340R keeps low.

MODEM liaison signal pins contain: CTS#, DSR#, RI#, DCD# and RTS#. All these MODEM liaison signal are controlled and function defined by computer applications.

Assistant pins contain: IR#, R232, CK0, ACT# and TNOW. When IR# is low-level, infrared serial interface mode is enabled. R232 pin is used to control assistant RS232 function. If R232 pin is driven high, the RXD pin input will be reversed automatically. ACT# pin is USB device configuration complete status output (such as USB infrared adapter ready). TNOW pin indicates CH340 is transmitting data from UART when it is high-level and becomes low when transmit over. In RS485 and other half-duplex mode, TNOW could be used to indicate UART transmit-receive status. IR# and R232 are detected only once when chip powered on and reset.

CH340 has built-in separate transmit-receive buffer and supports simplex, half-duplex and full duplex UART communication. Serial data contains one low-level start bit, 5, 6, 7 or 8 data bits and 1 or 2 high-level stop bits, supports odd/even/mark/space check. CH340 supports common baud rate:

50, 75, 100, 110, 134.5, 150, 300, 600, 900, 1200, 1800, 2400, 3600, 4800, 9600, 14400, 19200, 33600, 38400, 56000, 57600, 76800, 115200, 128000, 153600, 230400, 460800, 921600, 1500000, 2000000 etc.

The baud rate error of CH340 UART reception allows not less than 2%, the baud rate error of CH340G/CH340T/CH340R UART transmission is less than 0.3%, less than 1% for CH340C/CH340E/CH340B.

In the Windows operation system, CH340 driver can emulate standard serial port. So the mostly original serial applications are totally compatible, without any modification.

CH340 can be used to upgrade the serial interface peripherals, or expand extra serial port for computers via USB bus, through external level conversion chip provide further RS232, RS485, RS422 interface, etc.

Only need to add infrared transceiver, CH340R can expand SIR infrared adapter for computer via USB bus, realize infrared communication between computer and peripheral equipment that comply with IrDA specifications.

6. Parameter

6.1 Absolute maximum rating (Critical or exceeding absolute maximum can cause permanent damage to device)

Name	Parameter Description		Min.	Max.	Units
TA	Ambient temperature	CH340G/CH340T/CH340R	-40	85	℃

		CH340C/CH340E/CH340B	-20	70	°C
TS	Storage temperature		-55	125	°C
VCC	Supply Voltage(VCC connects to power, GND to ground)		-0.5	6.0	V
VIO	The voltage of input or output pin		-0.5	VCC+0.5	V

6.2. Electrical Parameter (test conditions: TA=25°C, VCC=5V, exclude pin connected to USB bus)
(All the current parameters should multiply the coefficient of 40% when the power is 3.3V)

Name	Parameter Description		Min.	Typical	Max.	Units	
VCC	Supply Voltage	V3 doesn't connect to VCC	4.0	5	5.3	V	
		V3 connect to VCC	CH340G/T/R	2.8	3.3		3.6
			CH340C/E/B	3.0	3.3		3.6
ICC	Operating Supply Current(Normal Operation)		CH340G/C/E/T/R		7	20	mA
			CH340B		6	15	
ISLP	Operating Supply Current(USB Suspend)		VCC=5V		0.1	0.2	mA
			VCC=3.3V		0.09	0.15	
VIL	Low-level Input Voltage		-0.5		0.7	V	
VIH	High-level Input Voltage		2.0		VCC+0.5	V	
VOL	Low-level Output Voltage(4mA draw current)				0.5	V	
VOH	High-level Output Voltage(3mA output current) (Output 100uA current during chip reset)		VCC-0.5			V	
IUP	Input current input with built-in pull-up resistor		3	150	300	uA	
IDN	Input current input with built-in pull-down resistor		-50	-150	-300	uA	
VR	Restrict voltage when power-up reset		2.4	2.6	2.8	V	

6.3. Sequence Parameter (test conditions: TA=25°C, VCC=5V)

Name	Parameter Description	Min.	Typical	Max.	Units
FCLK	Frequency of input clock in XI	11.98	12.00	12.02	MHz
TPR	Reset time of power-up	20	35	50	mS

7. Application

7.1.1 USB to RS232 Converter Configuration using **CH340T**

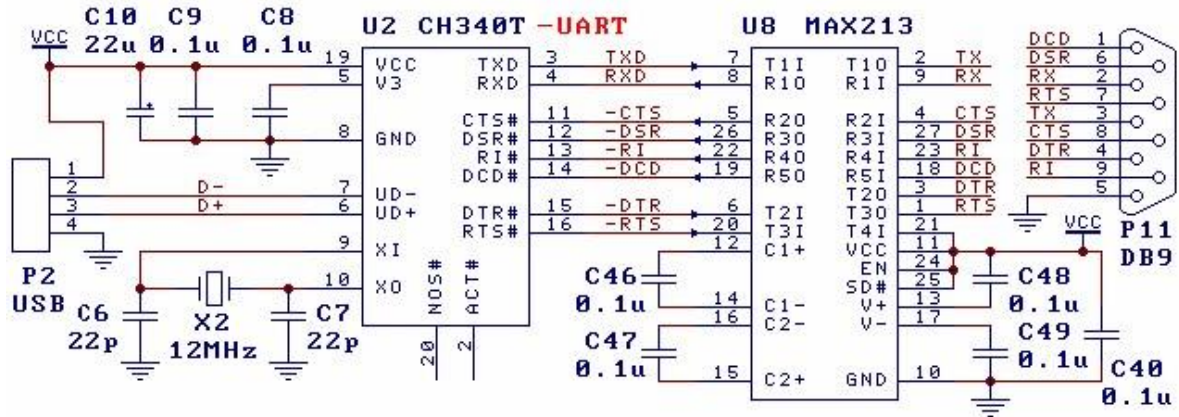

7.1.2 USB to RS232 Converter Configuration using CH340B

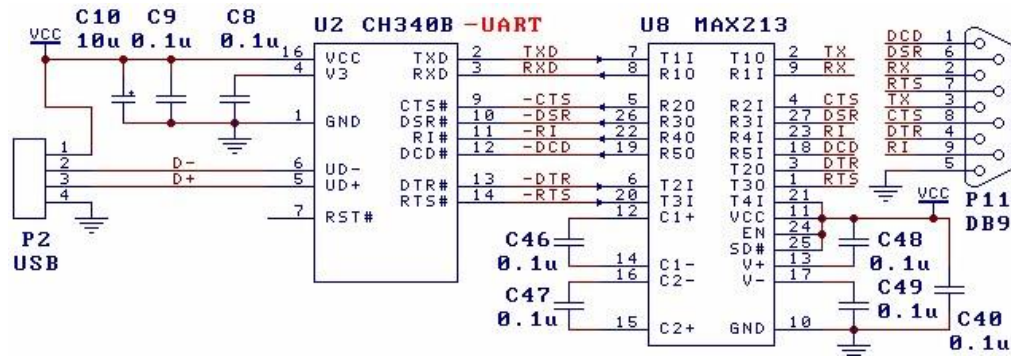

The image above use CH340T/CH340B (or CH340C) to realize USB to RS232 converter. CH340 provides common UART and MODEM signal, converts TTL to RS232 through level conversion chip U8. Port P11 is DB9 connector, the pin and its function are the same as common PC DB9 connector, the chips similar with U8 have MAX213/ADM213/SP213/MAX211 etc.

U8 and C46/C47/C48/C49/C40 could be removed when realize USB to TTL converter only. The signal lines in the image only RXD、 TXD and public ground need connected, the other signal lines should suspend when not use.

P2 is USB port, USB bus contains a pair of 5V power lines and a pair of data signal lines . Usually, the color of +5V power line is red, the black one is ground. D+ signal line is green and the D- signal line is white. The max supply current of USB bus is up to 500mA. Generally, CH340 and low power consumption USB products can use the 5V power supplied by USB bus directly. If the USB products supply standing power by other manner, CH340 should use this power too. If the USB bus power and standing power are necessary at the same time, connect a 1Ω resistor between USB bus 5V power line and USB products 5V standing power line, and connect the ground lines of these two power directly.

The capacitor C8 on V3 pin is 0.1uF, used to CH340 internal power node decoupling. The capacitor C9 is 0.1uF, used to external power decoupling.

For CH340G/T/R chip, Crystal X2, capacitor C6 and C7 are used for clock oscillation circuit. The X2 is 12MHz quartz crystal, C6 and C7 are monolithic or high frequency ceramic capacitors with 22pF. If X2 is ceramic with low cost, C6 and C7 must use the recommended value of crystal manufacturer and generally is 47pF. For the crystal which is difficult to oscillate, halved value is suggested for C6.

For CH340C/E/B chip, crystal X2 and capacitor C6, C7 are not required.

When designing the PCB, pay attention to: decoupling capacitor C8 and C9 must keep near to connection pin of CH340; makes sure D+ and D- signal lines are parallel and supply ground lines or pour copper beside them to decrease the interference from outside signal; the signal lines relevant to XI and XO should be kept as short as possible. In order to lessen the high frequency interference, around the ground wire or pour copper around the relevant components.

7.2. USB to RS232 Converter Configuration (3-wire)

The image below is USB to 3-wire RS232 converter design which is the most basic and most commonly used, U5 uses MAX232/ICL232/SP232 etc.

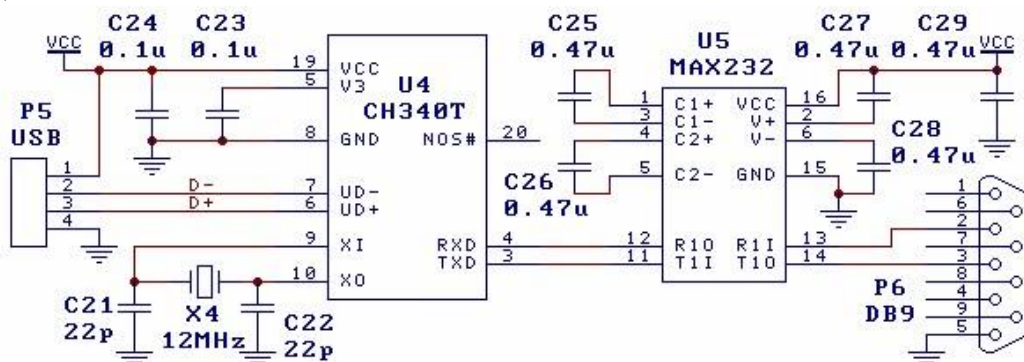

7.3 USB to RS232 Converter Configuration (Simplified version using R232)

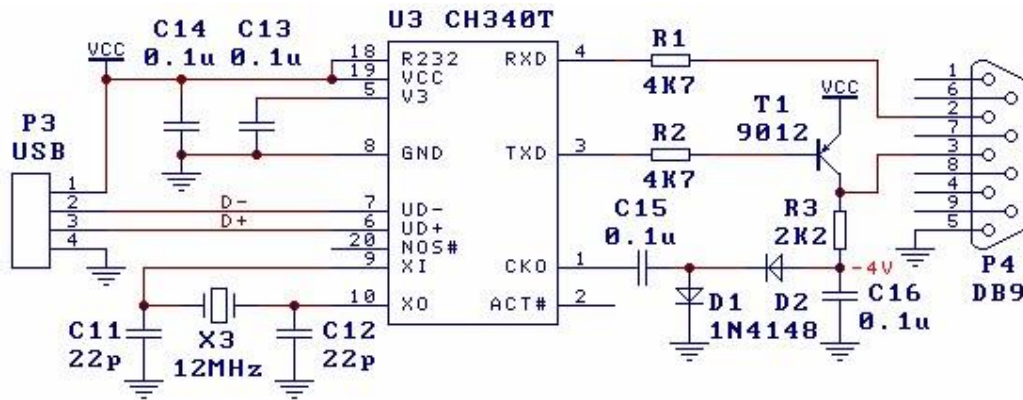

The image above is USB to RS232 converter design too, the function of this circuit is the same with 7.2 section except the range of output RS232 is narrower. When R232 pin is driven high, the assistant RS232 function will be enabled, just need to add some diodes, transistors, resistors and capacitors, the special level conversion chip U5 in section 7.2 could be replaced and the hardware cost is lower.

7.4 USB to Infrared Adapter

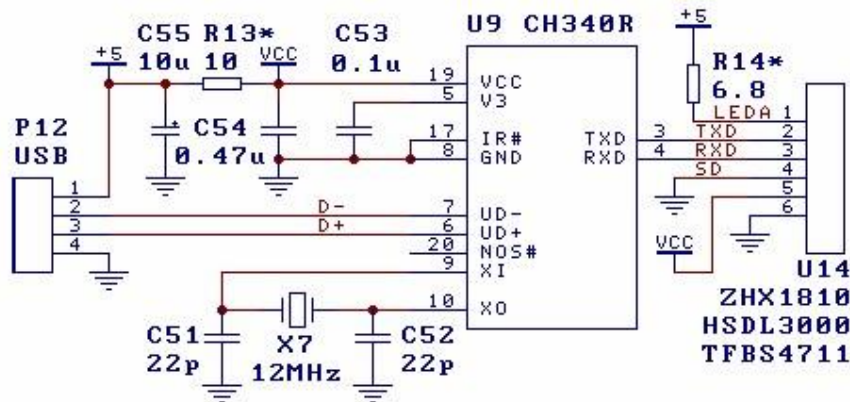

The image above is USB to infrared adapter design is composed with USB convert IrDA infrared chip CH340R and infrared transceiver U14 (ZHX1810/HSDL3000 etc).The resistor R13 is used to weaken influence of large current in infrared transmitting. The current limiting resistor R14 should be adjusted according to the manufacturer's recommended value of the infrared transceiver U14.

7.5. USB to RS485 Converter Configuration

The TNOW pin can be used to control DE (high active send enable) and RE# (low active receive enable) pin of RS485 transceiver.