

W3230 Microcomputer Temperature Controller

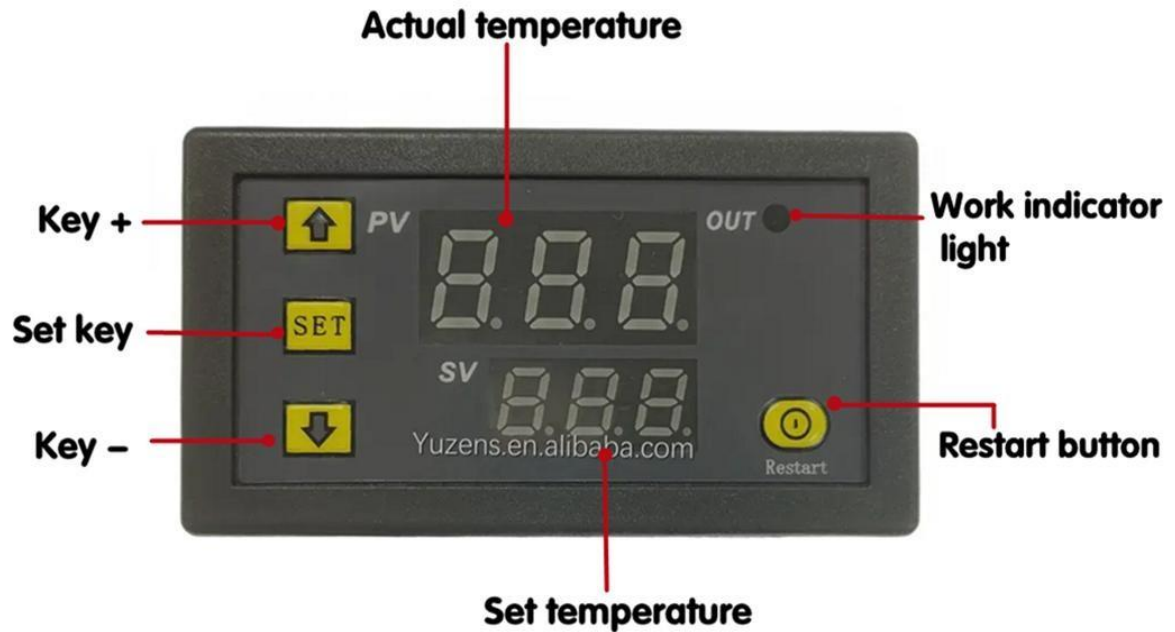

Product Parameters

Name	W3230 Temperature Controller
Temperature Control Range	-55°C ~ 120°C
Resolution ratio	0.1°C at -9.9°C~99.9°C, 1°C at other temperature ranges
Temperature measurement accuracy	0.1°C
Control accuracy	0.1°C
Return accuracy	0.1°C
Input power supply	DC5V/12V/24V/AC110-220V (optional)
Refresh frequency	About 0.5S

Detection probe	NTC waterproof probe 1M
Output	1-way relay output, capacity=20A
Environmental requirements	-10°C~60°C Humidity 20%~85%
Dimensions	79*43MM*26MM

12V wiring method

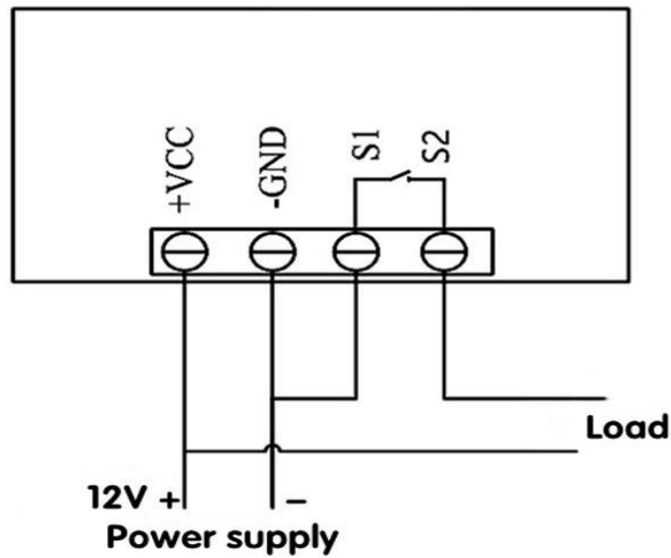

110-220V wiring method

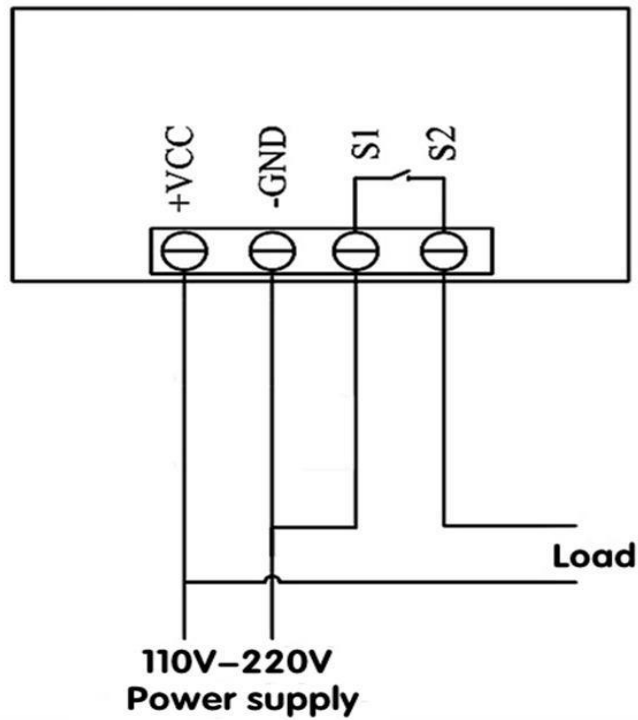

Code Settings	
P0	Cooling/Heating
P1	Return setting 0.1-30°C
P2	Maximum temperature setting upper limit 120
P3	Lowest temperature limit -55
P4	temperature correction
P5	Delay start time (Unit: minutes) 0-10min
P6	Alarm temperature setting -55~120
P7	Data locking function ON/OFF
P8	Restore factory settings

Usage method:

After connecting the power supply and equipment, power can be supplied to the controller. At this time, the display shows the measured temperature.

Press the SET button once, and the display screen temperature will flash.

Press+ - to set the required temperature (press and hold+ - to quickly rise and

fall). After the setting is completed, press the SET button to confirm and

return. At this time, the controller will automatically execute the relay on/off

according to the setting! The output of the temperature controller is a 20A

relay, which meets various high-power loads. After connecting the control

circuit, the temperature controller can be powered, and the display screen

shows the ambient temperature.

Status description of indicator light and Nixie tube:

Indicator light: flashing indicates a delay in starting cooling or heating, and a constant light indicates that the relay is closed

Nixie tube: LL indicates that the sensor is open circuit, please connect the sensor according to the instructions; The display HH indicates that the temperature controller will forcibly disconnect the relay if it exceeds the measurement range; Display - - High temperature alarm.

Parameter Function Description:

Press and hold SET for 5 seconds to enter the main menu settings. Press+to switch between P0... P6. Press and hold SET for 10 seconds or the controller will automatically confirm and return without any button action.

P0 cooling and heating modes:

Press and hold SET for 5 seconds to display P0. Press and hold SET once to set the working mode. Press+- to switch between [H for heating mode] and [C for cooling mode]. Press and hold SET once to return. Press and hold SET for 10 seconds or the controller will automatically confirm the completion of no button action.

In refrigeration mode: when the temperature measurement value is \geq the temperature set point, the refrigeration relay is engaged and the refrigerator starts; When the temperature measurement value is \leq the temperature set point return difference, the refrigeration relay is disconnected and the refrigerator is turned off.

In heating mode: when the temperature measurement value is \leq the temperature set point, the heating relay is engaged and the heater starts; When the temperature measurement value is \geq the temperature set point+return difference, the heating relay is disconnected and the heater is turned off.

P1 return difference setting:

Press and hold SET for 5 seconds to display P0, press+- to switch to P1, press SET once to set the return difference, press+- to set the return difference to 0.1-15, and then press SET once to return. Press and hold SET for 10 seconds or the controller will automatically confirm the completion of the keyless action.

In refrigeration mode: when the temperature measurement value is \geq the set value, the relay is engaged and the refrigerator starts; When the temperature measurement value is less than or equal to the set value return difference, the relay is disconnected and the refrigerator is turned off.

For example, if the environment is set to 30 °C and the temperature difference is set to 25 °C, the relay will close and the refrigerator will start after being powered on. When the cooling reaches 23 °C, the relay will disconnect and the refrigerator will close. At this time, as the refrigerator has already been disconnected, the temperature will start to rise. When the temperature rises

to the set value of 25 °C, the relay will close and the refrigerator will start again, and the temperature will be controlled repeatedly to not exceed 25 °C.

In heating mode: when the temperature measurement value is \leq the set value, the relay is engaged and the heater starts; When the temperature measurement value is \geq the set value+return difference, the relay is disconnected and the heater is turned off.

For example, when the environment is set to 10 °C and the value is set to 25 °C, the return difference is set to 2 °C. After being powered on, the relay closes and the heater starts to start. When the heating reaches 27 °C, the relay disconnects and the heater turns off. At this time, the temperature starts to decrease because the heater has already been disconnected. When the setting value is 25 °C, the relay closes and the heater starts again. This repeatedly controls the temperature not to be lower than 25 °C.

P2 high temperature setting upper limit:

To avoid the danger of setting the temperature too high due to misoperation by others, this temperature controller has a high setting upper limit function, which limits the setting range of the high temperature set point controlled by the temperature controller.

Press and hold SET for 5 seconds to display P0, press+- to switch to P2, press SET once to set the high upper limit, press+- to set the high temperature that can be set, with a maximum value of 110. After completion, press SET once to

return, press and hold SET for 10 seconds or the controller will automatically confirm the completion of the keyless action.

For example, if the temperature set point is set to 60 ° C, it can only be set to 60 ° C. If you want the temperature set point to be higher and the temperature range to be expanded, you need to first adjust the upper limit setting value.

P3 Low temperature setting lower limit:

To avoid ice blockage caused by improper operation by others, this temperature controller has a low setting upper and lower limit function, which limits the setting range of the low temperature set point controlled by the temperature controller.

Press and hold SET for 5 seconds to display P0, press+- to switch to P3, press SET once to set the low limit, press+- to set the low temperature that can be set, with a low value of -50. After completion, press SET once to return, press and hold SET for 10 seconds or the controller will automatically confirm the completion of the keyless action.

For example, if the temperature set point is set to 2 ° C, it can only be set to 2 ° C. If you want the temperature set point to be lower and the temperature range to be expanded, you need to first adjust the lower limit setting value.

P4 temperature correction:

When there is a deviation between the measured temperature and the standard temperature or due to special hardware needs of the user, this function can be used for calibration. The corrected temperature=the temperature before calibration+the effective range of the calibration value is -7.0~7.0.

Press and hold SET for 5 seconds to display P0, press+- to switch to P4, press SET once to calibrate, press+- to set the calibration value, and press SET once to return. Press and hold SET for 10 seconds or the controller will automatically confirm the completion of no button action.

For example, the normal display is 25 degrees; Display 25 degrees when the temperature is corrected to 0; Display 26.5 degrees when the temperature is corrected to 1.5; Display 23.5 when the temperature correction is -1.5.

P5 delay start time (unit: minutes)

When there is a need for a delay in the operation of the refrigerator or heater, the delay function can be activated to protect the equipment's lifespan.

Press and hold SET for 5 seconds to display P0, press+- to switch to P5, press SET once to set the delay start time unit in minutes, press+- to set

0-10 minutes, press SET once to return, press and hold SET for 10 seconds, and the controller will automatically confirm the completion of no button action

In refrigeration mode: when powered on again, if the current temperature is \geq the set value, the refrigerator will not immediately start refrigeration and needs to run for a set delay time before starting.

In heating mode: secondary power on, if the current temperature is \leq the set value, the heater will not immediately start heating and needs to run for the set delay time before starting.

When the shutdown time between two adjacent starts of the refrigerator or heater is greater than the set value of the delayed start time, the refrigerator will start immediately.

When the shutdown time interval between two adjacent starts of a refrigerator or heater is less than the set value of the delayed start time, the equipment can only be started after the set delayed start time of the refrigerator has been run for another start. The delay time is calculated from the start of shutdown.

For example, in the cooling state, a delay of 5 minutes is set. After starting the refrigerator, there is a delay in starting it. After 5 minutes, when the required temperature is reached, the refrigerator stops and starts counting.

The next time the refrigerator starts counting is completed, it immediately starts working. If the timer is not completed, it must wait for the timer to

finish before working. During the delay, the LED indicator light flashes. When the delay start is set to 0, it is equivalent to turning off the delay function.

How to save settings:

To save the set data, set **P7** to ON when the temperature is set and the power is continuously turned on. This way, the last setting will be retained regardless of the power outage.

How to restore factory settings:

Due to some human error, the internal settings of the temperature controller are chaotic, and setting each item one by one is time-consuming. At this time, this function can be used to restore the factory settings. The specific method is to press and hold the + and buttons in the shutdown state, and then turn on the machine. All the above parameters are restored to the factory settings.



Yuzens.en.alibaba.com



Yuzens.en.alibaba.com

