

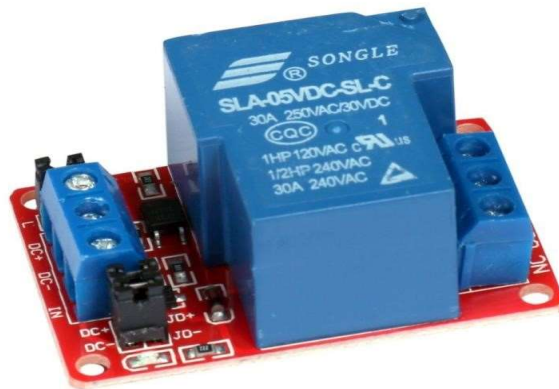

الحمادي للإلكترونيات  
ALHAMMADI FOR ELECTRONICS

## 1 Channel Relay Board 5V 30A



The Single-channel 5V 30A Relay Module power failure relay is a 1-channel relay module board with LED indicators, It can be controlled by microcontrollers such as Arduino, AVR, PIC, ARM any other microcontroller operating at 5V.

The relay module uses an authentic quality mechanical relay and the industry's top quality subminiature two-way isolation optical coupling which gives you the strong anti-interference ability, and stable performance.

The user can choose the relay control level, can be a high level off, also can be low level and off. The Songle Single-channel 5V 30A Relay Module Power Failure Relay contains a limited flow resistance, can directly use the power supply is negative control, you can also use the MCU I/O control.

The relay module equips a power indicator light (red), 1 road relay status indicator light (blue). With this relay, you can easily control electrical appliances, lights, etc. Fault-tolerant design, even if the control line is brokes, the relay will not move.

## **FEATURES:**

- Optical coupling isolation, driving ability is strong, stable performance; Trigger current is 5mA
- The module can be set high level or low-level trigger by the jumper
- Rated current of the interface is 16A
- DC+ and JD+ shorted by jumper cap, DC- and JD- shorted with jumper cap, it is the same voltage between trigger terminal and relay control terminal.
- High and low-level trigger mode selection. Jumper and L pin connection, IN pin, is lowlevel triggerJumper and H pin connection, IN pin, is the high-level trigger.

## **SPECIFICATIONS:**

- Trigger Voltage (VDC): 5
- Trigger Current (mA): 20
- Switching Voltage (VAC): 250@30A
- Switching Voltage (VDC): 30@30A
- Length (mm): 50
- Width (mm): 33
- Height (mm): 24
- Weight (gm): 36

## FUNCTIONAL DESCRIPTION:

- Relays are most commonly used switching device in electronics. It has two important parameter of the relay. One is the Trigger Voltage, this is the voltage required to turn on the relay that is to change the contact from Common->NC to Common->NO. This relay here has 5V trigger voltage or current that the NC,NO or Common terminal of the relay could withstand, in this case for DC it is maximum of 30V and 10A. Make sure the load you are using falls into this range.

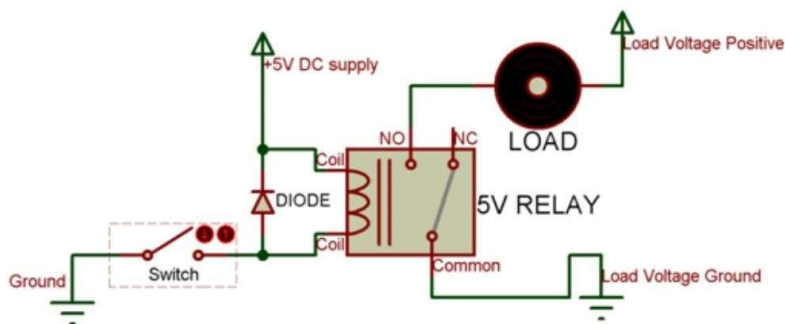

- The above circuit shows a bare-minimum concept for a relay to operate. Since the relay has 5V trigger voltage we have used a +5V DC supply to one end of the coil and the other end to ground through a switch. This switch can be anything from a small transistor to a microcontroller or a microprocessor which can perform switching operating. You can also notice a diode connected across the coil of the relay, this diode is called the Fly back Diode. The purpose of the diode is to protect the switch from high voltage spike that can be produced by the relay coil. As shown one end of the load can be connected to the Common pin and the other end is either connected to NO or NC. If connected to NO the load remains disconnected before trigger and if connected to NC the load remains connected before trigger.

**PIN FUNCTION:**

- DC+: DC power supply positive pole
- DC-: DC power supply negative pole
- IN: Signal triggering pin
- JD+: Relay control voltage positive
- JD-: Relay control voltage negative
- DC+ and JD+ shorted by jumper cap, DC- and JD- shorted with jumper cap, it is the same voltage between trigger terminal and relay control terminal
- High and low level trigger mode selection. Jumper and L pin connection, IN pin is low level trigger Jumper and H pin connection, IN pin is high level trigger
- Normally closed pin (NC): relay normally closed pin
- Common pin (COM): relay common pin
- Normally opened pin (NO): relay normally opened pin

**PACKAGE INCLUDES:**

1x 1 Channel Relay Board 5V 30A