



Note:

Lithium battery protection board can not be used for lithium iron phosphate batteries, hernia lights, hand drill battery packs, can not be used for electric fish machine battery packs, electric bicycle battery packs, children's car batteries, 550 or more power motors, 1W fisheye LED lights, customers who use the above combinations to purchase please note!.

The described power range applies to the following products:

Massager battery pack, LED light backup power, 12V electronics, solar street light battery pack, monitoring backup power, and other products.

Key features:

Overcharge protection, over-discharge protection, short-circuit protection, over-current protection

Wiring Instructions:

B+ is connected to the positive terminal of the battery

B- Connect the negative electrode of the battery

MB Connect the connection point between battery 1 and battery 2

P+ Positive Terminal/Charger/Discharge Terminal (Common)

P- Negative pole of the connection/discharge end (common to the charge/discharge end)

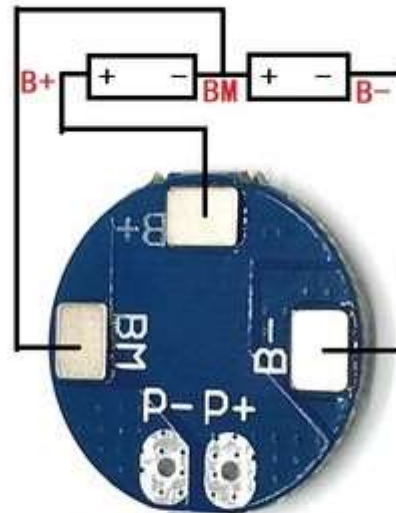

P+P-是输入输出同口，组合时电池电压，容量，内阻都要配对好，电池电压在额定电压3.7V左右合适，组合好后没有输出，用8.4V电压充电即可。

frequently asked questions

1. Can I use your protective board for my battery?

Answer: There are two questions to consider whether you can use this protection board: first, how many strings of your battery is, you have to buy the protection board with the corresponding number of strings. Second, what material is your battery? We have lithium iron phosphate and polymer lithium battery two parameters of the protection board, if your battery is lithium iron phosphate single cell nominal 3.2V, you need to choose lithium iron phosphate 3.2V in the classification, if it is polymer

(ternary, cobalt acid, lithium manganese oxide) single cell battery nominal 3.6V (or 3.7V), please choose the polymer 3.7V classification.

2. How can I tell what material my battery is made of?

A: You can take a look at the nominal voltage of your battery, lithium iron phosphate batteries are generally marked 3.2V, other batteries are generally marked 3.6V or 3.7V, you can also directly ask the seller who sells the battery what material the battery is, many buyers say that my battery is 18650 or 26650 soft pack, etc., this is the shape, not the material! We can't determine your battery protection parameters based on this.

3. How many A protection boards should I choose?

Answer: The number of A protection boards to choose depends on the power of your product or the current limit of the controller, such as 10A below 100W, 20A below 200W, 25A below 300W, and more than 500W, please contact the current of the protection board first, and the current of the protection board cannot be less than the current limit of the controller.

4. Can I use this protective board if my battery is 20AH?

Answer: The size of your battery capacity is not directly related to the current size of this board, the large capacity is not the size of the battery, the main thing is to see the continuous current, that is to say, the greater your power, the greater the continuous current of the protection board you choose, and your battery capacity is not directly related.

5. How should the charger voltage be set?

Lithium battery should be charged with a special charger for lithium battery, do not use a lead-acid battery charger, lead-acid charging may have a high-voltage breakdown of the MOS tube of the protection board, resulting in overcharging of the protection board without protection.

Charger voltage setting: use the number of your battery pack strings * 4.2V This is the charging voltage of the non-ferrous lithium battery, the charging voltage of the lithium iron battery is the number of battery strings * 3.60V This is the charging voltage of the lithium iron battery, and the charging current standard is 0.2 times the capacity.