

## G2R

## PCB Power Relay

### The Best Seller G2R

- 1General purpose power Relays of single-pole 10 A and double-pole 5 A.
- Safety-oriented design with dielectric strength of 5,000 V between coil and contacts, and surge resistance of 10,000 V.
- AC and DC types are both available for operational coils.



### Model Number Legend

G2R-  $\frac{1}{2345}$   $\frac{67}{}$

#### 1. Relay Function

None: Single-side stable  
K : Double-winding latching

#### 2. Number of poles

1: 1-pole  
2: 2-pole

#### 3. Contact Form

None: NO/NC  
A : NO

#### 4. Contact Type

None: Single  
Z : Bifurcated contact

#### 5. Enclosure rating

None:  
Flux protection  
(T-type is an enclosed relay)  
4 : Fully sealed

#### 6. Terminal Shape

None: PCB terminals  
T : Quick-connect  
(upper bracket mounting #187)

#### 7. Classification

None: Standard  
E : High-capacity  
H : High-sensitivity  
U : For ultrasonically cleanable  
Z : Full-wave rectifier

G  
2  
R

### Model Configuration

Terminal Shape	Classification	Number of poles		1-pole		2-pole		Minimum packing unit
		Enclosure	Contact rating form	SPST-NO (1a)	SPDT (1c)	DPST-NO (2a)	DPDT (2c)	
PCB terminals	Standard	Flux protection	AC	G2R-1A	G2R-1	G2R-2A	G2R-2	100 pcs/tray
			DC					
		Fully sealed	AC	G2R-1A4	G2R-14	G2R-2A4	G2R-24	
			DC					
	Bifurcated contact	Flux protection	DC	G2R-1AZ	G2R-1Z	-	-	50 pcs/tray
				Fully sealed	G2R-1AZ4	G2R-1Z4	-	
	High-capacity	Flux protection	AC	G2R-1A-E	G2R-1-E	-	-	100

# G2R

## PCB Power Relay

			DC					pcs/tray
	High-sensitivity	Flux protection	DC	G2R-1A-H	G2R-1-H	G2R-2A-H	G2R-2-H	
	Double-winding latching	Flux protection	DC	G2RK-1A	G2RK-1	G2RK-2A	G2RK-2	50 pcs/tray
Quick-connect	Standard	Unsealed	AC	G2R-1A-T	G2R-1-T	-	-	100 pcs/tray
			DC					

Note 1. Full-wave rectifier and supersonic cleaner compatible models are also available. Refer to page 3.  
 2. Sockets for PCB terminal models are not provided.

## ■ Ordering Information

- PCB Terminal Models

Classification			1-pole		2-pole	
			Model	Rated coil voltage	Model	Rated coil voltage
<b>G2R</b>	Standard	Flux protection	<b>G2R-1A</b>	12, 24, 100/(110) VAC	<b>G2R-2A</b>	12, 24, 100/(110) VAC
				200/(220) VAC		200/(220) VAC
				5, 6, 12, 24, 48 VDC		5, 6, 12, 24, 48 VDC
				100 VDC		100 VDC
		NO/NC	<b>G2R-1</b>	12, 24, 100/(110) VAC	<b>G2R-2</b>	12, 24, 100/(110) VAC
				200/(220) VAC		200/(220) VAC
				5, 6, 12, 24, 48 VDC		5, 6, 12, 24, 48 VDC
				100 VDC		100 VDC
	Fully sealed	NO	<b>G2R-1A4</b>	12, 24, 100/(110) VAC	<b>G2R-2A4</b>	12, 24, 100/(110) VAC
				200/(220) VAC		200/(220) VAC
				5, 6, 12, 24, 48 VDC		5, 6, 12, 24, 48 VDC
				100 VDC		100 VDC
		NO/NC	<b>G2R-14</b>	12, 24, 100/(110) VAC	<b>G2R-24</b>	12, 24, 100/(110) VAC
				200/(220) VAC		200/(220) VAC
				5, 6, 12, 24, 48 VDC		5, 6, 12, 24, 48 VDC
				100 VDC		100 VDC
High-sensitivity	Flux protection	NO	<b>G2R-1A-H</b>	5, 6, 12, 24, 48 VDC	<b>G2R-2A-H</b>	5, 6, 12, 24, 48 VDC
		NO/NC	<b>G2R-1-H</b>	5, 6, 12, 24, 48 VDC	<b>G2R-2-H</b>	5, 6, 12, 24, 48 VDC
Double-winding latching	Flux protection	NO	<b>G2RK-1A</b>	5, 6, 12, 24 VDC	<b>G2RK-2A</b>	5, 12, 24 VDC
		NO/NC	<b>G2RK-1</b>	5, 6, 12, 24 VDC	<b>G2RK-2</b>	5, 6, 12, 24 VDC
Bifurcated contact	Flux protection	NO	<b>G2R-1AZ</b>	12, 24, 48 VDC	-	
				100 VDC		
		NO/NC	<b>G2R-1Z</b>	5, 6, 12, 24, 48 VDC		
				100 VDC		
	Fully sealed	NO	<b>G2R-1AZ4</b>	5, 12, 24, 48 VDC		
				100 VDC		
NO/NC		<b>G2R-1Z4</b>	5, 12, 24, 48 VDC			
			100 VDC			
High-capacity	Flux protection	NO	<b>G2R-1A-E</b>	12, 24, 100/(110) VAC	-	
				200/(220) VAC		
				5, 6, 12, 24, 48 VDC		

**PCB Power Relay**

# G2R

# PCB Power Relay

				100 VDC	
				12, 24, 100/(110) VAC	
				200/(220) VAC	
		NO/NC	<b>G2R-1-E</b>	5, 6, 12, 24, 48 VDC	-
				100 VDC	

G  
2  
R

Note: When ordering, add the rated coil voltage to the model number.  
Example: G2R-1AAC12

  
Rated coil voltage

However, the notation of the coil voltage on the product case as well as on the packing will be marked as  $\cong$  VAC.

● **Quick-connect Terminal (#187)**

Classification	Enclosure rating	Number of poles Contact form	1-pole	
			Model	Rated coil voltage
Standard	Unsealed	NO	<b>G2R-1A-T</b>	12, 24, 100/(110) VAC
				200/(220) VAC
				5, 6, 12, 24, 48 VDC
				100 VDC
		NO/NC	<b>G2R-1-T</b>	12, 24, 100/(110) VAC
				200/(220) VAC
				5, 6, 12, 24, 48 VDC

# G2R

## PCB Power Relay

100 VDC

### ● Full-wave Rectifier

		Number of poles Contact form	1-pole		2-pole	
Classification	Enclosure rating		Model	Rated coil voltage	Model	Rated coil voltage
Standard	Flux protection	NO	G2R-1A-Z	5, 12, 24 VDC	G2R-2A-Z	5, 6, 12, 24, 48 VDC
				100 VDC		100 VDC
	NO/NC	G2R-1-Z	5, 12, 24, 48 VDC	G2R-2-Z	12, 24, 48 VDC	
			100 VDC		100 VDC	
	Fully sealed	NO	G2R-1A4-Z	5, 12, 48 VDC	G2R-2A4-Z	24, 48 VDC
				100 VDC		100 VDC
NO/NC	G2R-14-Z	5, 12, 24, 48 VDC	G2R-24-Z	5, 12, 24 VDC		
		100 VDC		100 VDC		
High-capacity	Flux protection	NO	G2R-1A-EZ	5, 12, 24 VDC		-
				100 VDC		
		NO/NC	G2R-1-EZ	12, 24, 48 VDC		

G  
2  
R

### ● For Ultrasonically Cleanable

		Number of poles Contact form	1-pole		2-pole	
Classification	Enclosure rating		Model	Rated coil voltage	Model	Rated coil voltage
Standard	Fully sealed	NO	G2R-1A4-U	12, 24, 100/(110) VAC	G2R-2A4-U	100/(110) VAC
				200/(220) VAC		-
				5, 6, 12, 24, 48 VDC		5, 12, 24 VDC
		NO/NC	G2R-14-U	100/(110) VAC	G2R-24-U	24, 100/(110) VAC
				200/(220) VAC		200/(220) VAC
				5, 12, 24, 48 VDC		5, 12, 24, 48 VDC
				100 VDC		100 VDC

Note: When ordering, add the rated coil voltage to the model number.

Example: G2R-1A-TAC12



Rated coil voltage

However, the notation of the coil voltage on the product case as well as on the packing will be marked as  $\cong$  VAC.

## ■ Ratings

### ● Coil

Classification	Item Rated voltage	Rated current (mA)		Coil resistance ( $\Omega$ )	Must operate voltage (V)	Must release voltage (V)	Max. voltage (V)	Power consumption (VA, W)
		50 Hz	60 Hz					
<ul style="list-style-type: none"> <li>• Standard</li> <li>• Quick-connect</li> <li>• Fully sealed</li> <li>• High-capacity</li> </ul>	12 VAC	93	75	65	80% max.	30% min.	140% (at 23°C)	Approx. 0.9 (60 Hz)
	24 VAC	46.5	37.5	260				
	100/(110) VAC	11	9/(10.6)	4,600				
	200/(220) VAC	5.5	4.5/(5.3)	20,200				
<ul style="list-style-type: none"> <li>• Standard</li> <li>• High-capacity</li> <li>• Bifurcated contact</li> <li>• Quick-connect</li> <li>• Fully sealed</li> </ul>	5 VDC	106		47	70% max.	15% min.	170% (at 23°C)	Approx. 0.53
	6 VDC	88.2		68				
	12 VDC	43.6		275				
	24 VDC	21.8		1,100				
	48 VDC	11.5		4,170				
	100 VDC	5.3		18,870				
<ul style="list-style-type: none"> <li>• High-sensitivity</li> </ul>	5 VDC	71.4		70	70% max.	15% min.	170% (at 23°C)	Approx. 0.36
	6 VDC	60		100				
	12 VDC	30		400				
	24 VDC	15		1,600				
	48 VDC	7.5		6,400				

Note 1. The rated current and coil resistance are measured at a coil temperature of 23°C with a tolerance of +15%/-20% (AC rated current) or  $\pm$ 10% (DC coil resistance).

G 2.AC coil resistances shown above are only reference values.

- 2 3.The operating characteristics are measured at a coil temperature of 23°C.  
 R 4.The "Max. voltage" is the maximum voltage that can be applied to the relay coil.

### ● Coil: Double-winding Latching Relays

Item	Set Coil		Reset coil		Must set voltage (V)	Must reset voltage (V)	Max. voltage (V)	Power consumption	
	Rated current (mA)	Coil resistance (Ω)	Rated current (mA)	Coil resistance (Ω)				% of rated voltage	
5 VDC	167	30	119	42	70% max.	70% max.	140% (at 23°C)	Approx. 850	Approx. 600
6 VDC	138	43.5	100	60					
12 VDC	70.6	170	50	240					
24 VDC	34.6	694	25	960					

Note 1. The rated current and coil resistance are measured at a coil temperature of 23°C with a tolerance of ±10%.

2.The operating characteristics are measured at a coil temperature of 23°C.

3.The "Max. voltage" is the maximum voltage that can be applied to the relay coil.

### ● Contacts: Flux Protection Type

Classification	Standard type Quick-connect Terminal (1single-pole type)				High-capacity type		Bifurcated contact type		High-sensitivity type					
	1-pole		2-pole		1-pole		2-pole		1-pole		2-pole			
Item	Resistive load	Inductive load (cosφ = 0.4; L/R = 7 ms)	Resistive load	Inductive load (cosφ = 0.4; L/R = 7 ms)	Resistive load	Inductive load (cosφ = 0.4; L/R = 7 ms)	Resistive load	Inductive load (cosφ = 0.4; L/R = 7 ms)	Resistive load	Inductive load (cosφ = 0.4; L/R = 7 ms)	Resistive load	Inductive load (cosφ = 0.4; L/R = 7 ms)	Resistive load	Inductive load (cosφ = 0.4; L/R = 7 ms)
Contact type	Single				Single		Bifurcated		Single					
Contact material	Ag-alloy (Cd free)													
Rated load	10 A at 250 VAC 10 A at 30 VDC	7.5 A at 250 VAC 5 A at 30 VDC	5 A at 250 VAC 5 A at 30 VDC	2 A at 250 VAC 3 A at 30 VDC	16 A at 250 VAC 16 A at 30 VDC	8 A at 250 VAC 8 A at 30 VDC	5 A at 250 VAC 5 A at 30 VDC	2 A at 250 VAC 3 A at 30 VDC	5 A at 250 VAC 5 A at 30 VDC	2 A at 250 VAC 3 A at 30 VDC	3 A at 250 VAC 3 A at 30 VDC	1 A at 250 VAC 1.5 A at 30 VDC		
Rated carry current	10 A		5 A		16 A		5 A		5 A		3 A			
Max. switching voltage	380 VAC, 125 VDC				380 VAC, 125 VDC				380 VAC, 125 VDC					
Max. switching current	10 A		5 A		16 A		5 A		5 A		3 A			
Failure rate (P level) (reference value) *	100 mA at 5 VDC		10 mA at 5 VDC		100 mA at 5 VDC		1 mA at 5 VDC		100 mA at 5 VDC		10 mA at 5 VDC			

\* This value was measured at a switching frequency of 120 operations/min.

## ● Contacts: Fully Sealed Type

Classification Number of poles Item	Standard type (Single contact type)				Bifurcated contact type	
	1-pole		2-pole		1-pole	
	Resistive load ( $\cos\phi = 1$ )	Inductive load ( $\cos\phi = 0.4$ ; L/R = 7 ms)	Resistive load ( $\cos\phi = 1$ )	Inductive load ( $\cos\phi = 0.4$ ; L/R = 7 ms)	Resistive load ( $\cos\phi = 1$ )	Inductive load ( $\cos\phi = 0.4$ ; L/R = 7 ms)
Contact type	Single		Single		Bifurcated	
Contact material	Ag-alloy (Cd free)					
Rated load	8 A at 250 VAC 8 A at 30 VDC	6 A at 250 VAC 4 A at 30 VDC	4 A at 250 VAC 4 A at 30 VDC	1.5 A at 250 VAC 2.5 A at 30 VDC	5 A at 250 VAC 5 A at 30 VDC	2 A at 250 VAC 3 A at 30 VDC
Rated carry current	8 A		4 A		5 A	
Max. switching voltage	380 VAC, 125 VDC		380 VAC, 125 VDC		380 VAC, 125 VDC	
Max. switching current	8 A		4 A		5 A	
Failure rate (P level) (reference value) *	100 mA at 5 VDC		10 mA at 5 VDC		1 mA at 5 VDC	

2 R

\* This value was measured at a switching frequency of 120 operations/min.

## ● Contacts: Latching Type

Number of poles Item	1-pole		2-pole	
	Resistive load ( $\cos\phi = 1$ )	Inductive load ( $\cos\phi = 0.4$ ; L/R = 7 ms)	Resistive load ( $\cos\phi = 1$ )	Inductive load ( $\cos\phi = 0.4$ ; L/R = 7 ms)
Contact type	Single		Single	
Contact material	Ag-alloy (Cd free)			
Rated load	5 A at 250 VAC 5 A at 30 VDC	3.5 A at 250 VAC 2.5 A at 30 VDC	3 A at 250 VAC 3 A at 30 VDC	1.5 A at 250 VAC 2 A at 30 VDC
Rated carry current	5 A		3 A	
Max. switching voltage	380 VAC, 125 VDC		380 VAC, 125 VDC	
Max. switching current	5 A		3 A	
Failure rate (P level) (reference value) *	100 mA at 5 VDC		10 mA at 5 VDC	

\* This value was measured at a switching frequency of 120 operations/min.

G

# G2R

## PCB Power Relay

### ■ Characteristics

#### ● Standard Relays

Item	Number of poles	1-pole	2-pole
Contact resistance *1		30 mΩ max.	50 mΩ max.
Operate time *2		15 ms max.	
Release time *2		AC: 10 ms max.; DC: 5 ms max.	
Max. operating frequency	Mechanical	18,000 operations/hr	
	Electrical	1,800 operations/hr	
Insulation resistance *3		1,000 MΩ min.	
Dielectric strength	Between coil and contacts	5,000 VAC, 50/60 Hz for 1 min	
	Between contacts of different polarity	-	3,000 VAC, 50/60 Hz for 1 min
	Between contacts of the same polarity	1,000 VAC, 50/60 Hz for 1 min	
Insulation distance	Between coil and contacts	Clearance: 8 mm, Creepage: 8 mm	
Vibration resistance	Destruction	10 to 55 to 10 Hz, 0.75 mm single amplitude (1.5 mm double amplitude)	
	Malfunction	10 to 55 to 10 Hz, 0.75 mm single amplitude (1.5 mm double amplitude)	
Shock resistance	Destruction	1,000 m/s <sup>2</sup>	
	Malfunction	200 m/s <sup>2</sup> when energized; 100m/s <sup>2</sup> when no energized	
Durability	Mechanical	AC coil: 10,000,000 operations min.; DC coil: 20,000,000 operations min. (at 18,000 operations/hr)	
	Electrical	100,000 operations min. (at 1,800 operations/hr under rated load)	
Ambient operating temperature		-40°C to 70°C (with no icing)	
Ambient operating humidity		5% to 85%	
Weight		Approx. 17 g (Approx. 20 g *4)	

### ■ Engineering Data

#### Double-winding Latching Relays

		30 mΩ max.	50 mΩ max.
Contact resistance *1			
Set	Time *2	20 ms max.	
	Min. set pulse width *3	30 ms	
Reset	Time *2	20 ms max.	
	Min. reset pulse width *3	30 ms	
Max. operating frequency	Mechanical	18,000 operations/hr	
	Electrical	1,800 operations/hr	
Insulation resistance *4		1,000 MΩ min.	
Dielectric strength	Between coil and contacts	5,000 VAC, 50/60 Hz for 1 min	
	Between contacts of different polarity	-	3,000 VAC, 50/60 Hz for 1 min
	Between contacts of the same polarity	1,000 VAC, 50/60 Hz for 1 min	
	Between set and reset coils	1,000 VAC, 50/60 Hz for 1 min	
Insulation distance	Between coil and contacts	Clearance: 8 mm, Creepage: 8 mm	
Vibration resistance	Destruction	10 to 55 to 10 Hz, 0.75 mm single amplitude (1.5 mm double amplitude)	
	Malfunction	10 to 55 to 10 Hz, 0.75 mm single amplitude (1.5 mm double amplitude)	
Shock resistance	Destruction	1,000 m/s <sup>2</sup>	
	Malfunction	Set: 500m/s <sup>2</sup> Armature OFF Reset: 200m/s <sup>2</sup> Contact OFF	
Durability	Mechanical	10,000,000 operations min (at 18,000 operations/hr)	
	Electrical	100,000 operations min. (at 1,800 operations/hr under rated load)	
Ambient operating temperature		-40°C to 70°C (with no icing or condensation)	
Ambient operating humidity		5% to 85%	
Weight		Approx. 17 g	

Item                      Number of poles                      1-pole                      2-pole

G  
2 R

Note: The values here are initial values.

- \*1. Measurement conditions: 5 VDC, 1 A, voltage-drop method.
- \*2. Measurement conditions: Rated operating voltage applied, not including contact bounce.
- \*3. Measurement conditions: The insulation resistance was measured with a 500 VDC megohmmeter at the same locations as the dielectric strength was measured.
- \*4. Value for quick-connect terminals.

# G2R

# PCB Power Relay

Note: The values here are initial values.

- \*1. Measurement conditions: 5 VDC, 1 A, voltage-drop method.
- \*2. Measurement conditions: Rated operating voltage applied, not including contact bounce.
- \*3. Measurement conditions: Rated operating voltage applied.

- \*4. Measurement conditions: The insulation resistance was measured with a 500 VDC megohmmeter at the same locations as the dielectric strength was measured.

## ● Maximum Switching Capacity Flux Protection/Plug-in Relays

### G2R-1, G2R-1A, G2R-1-T, G2R-1A-T

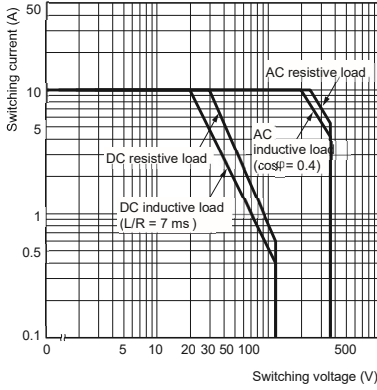

### G2R-1-E, G2R-1A-E

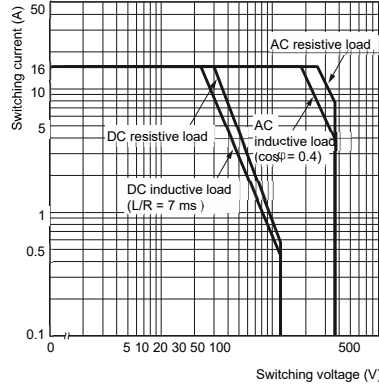

### G2R-1Z, G2R-1AZ

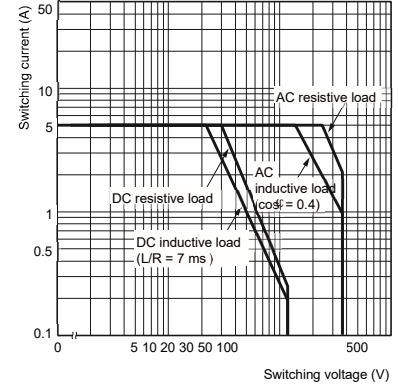

### G2R-1-H, G2R-1A-H, G2R-2, G2R-2A

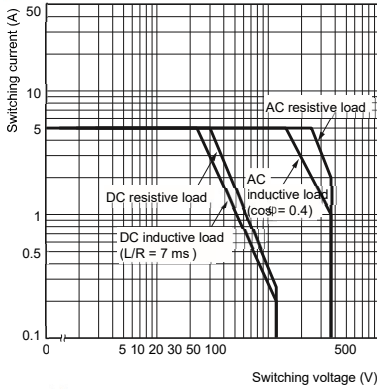

### G2R-2-H, G2R-2A-H

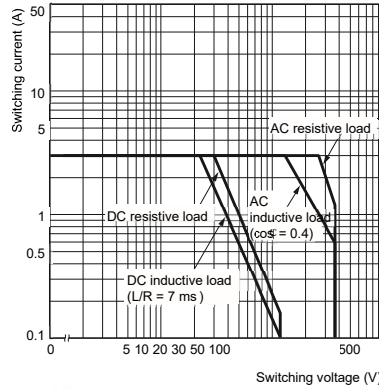

### G2RK-1A, G2RK-1

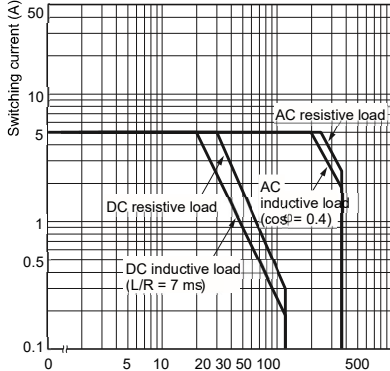

### G2RK-2A, G2RK-2

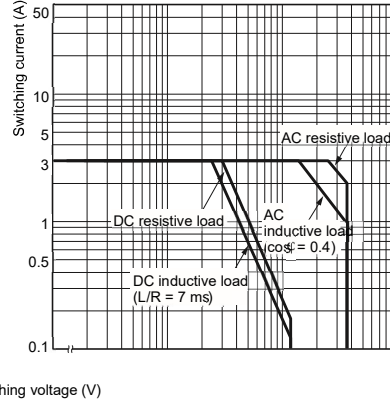

# G2R

# PCB Power Relay

## Fully Sealed Relays G2R-14, G2R-1A4

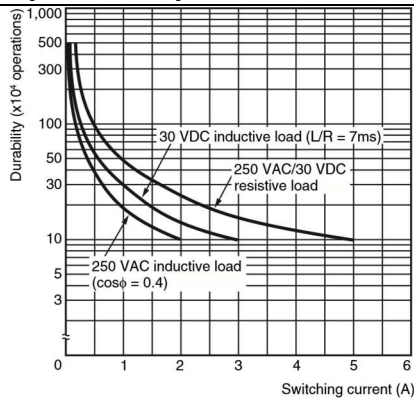

## ● Durability Flux Protection/Plug-in Relays G2R-1,

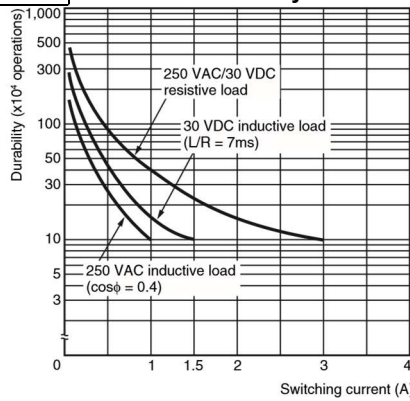

## G2R-1-E, G2R-1A-E

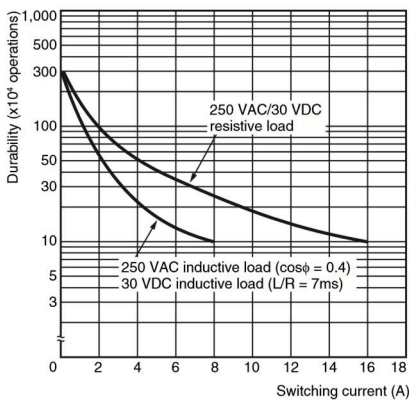

## G2R-1Z, G2R-1AZ

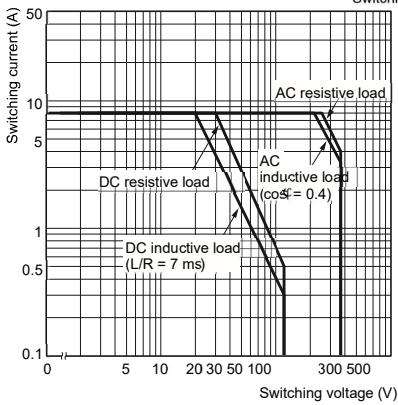
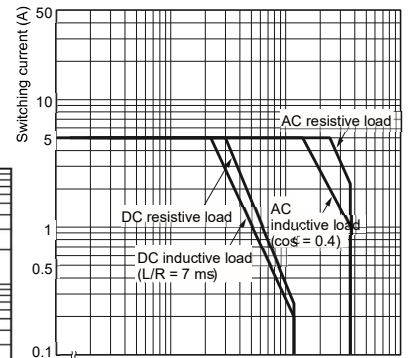
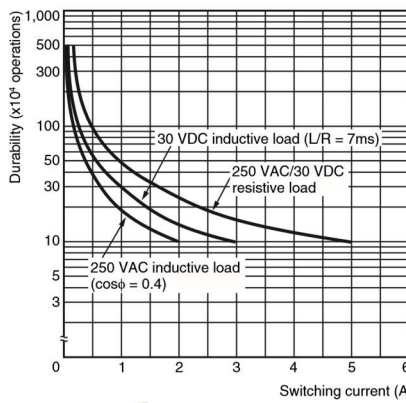

## G2R-1A, G2R-1-T, G2R-1A-T

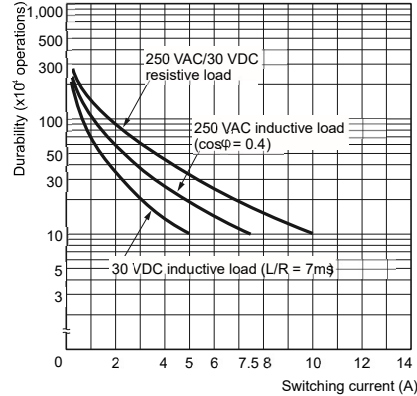

## G2R-1-H, G2R-1A-H, G2R-2, G2R-2A

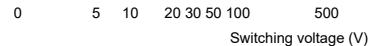

## G2R-24, G2R-2A4

## G2R-1Z4, G2R-1AZ4

G2R

# G2R

## PCB Power Relay

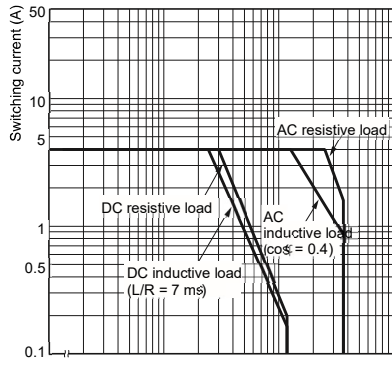

G2R-2-H, G2R-2A-H

# G2R

## G2RK-1A, G2RK-1

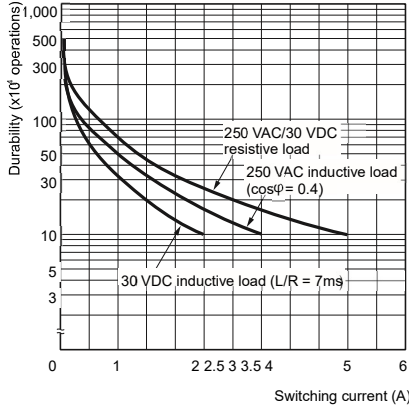

## G2RK-2A, G2RK-2

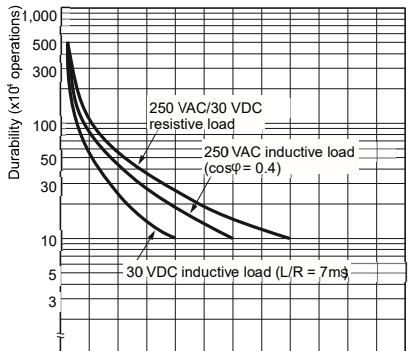
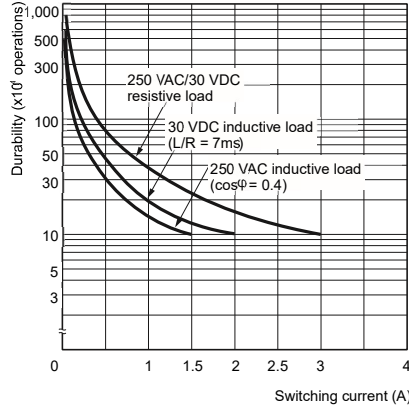

## Fully Sealed Relays G2R-14, G2R-1A4

## G2R-24, G2R-2A4

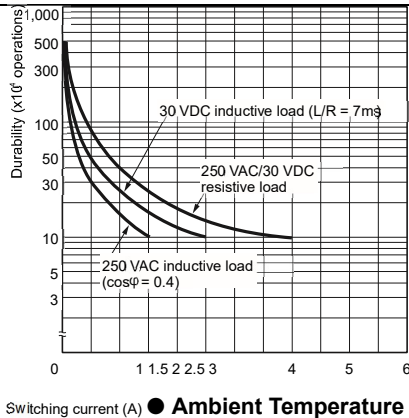

## vs. Maximum Ambient Temperature vs. Must Operate and Must Release Voltage

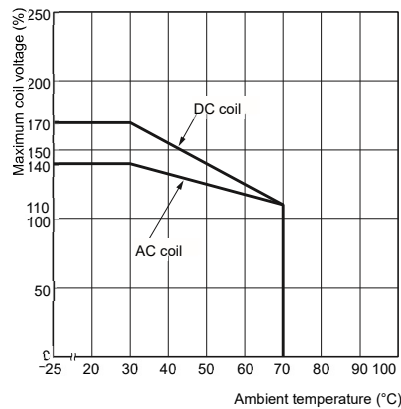

## G2R-1

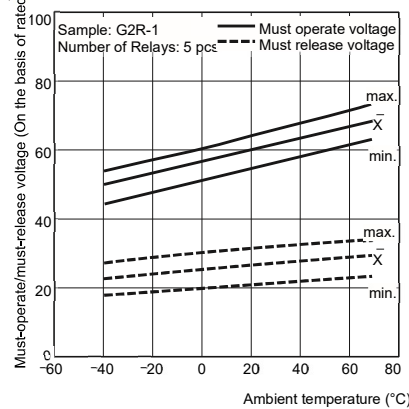

Note: The maximum coil voltage refers to the maximum value in a varying range of operating power voltage, not a continuous voltage.

# PCB Power Relay

## ● Shock Malfunction

G2R-1 Number of Relays: 5 pcs

G2R-2

Number of

Relays: 5 pcs

SPST-NO (1a)

SPST-NC (1c)

X

Z

Z

X

Y

1,000

800

600

400

200

200

400

600

800

1,000

Unit: m/s<sup>2</sup>

Shock direction

X ← X'

Y ↑ Y'

Z ⊙ Z'

Z ⊗ Z'

## G2R-1Z4, G2R-1AZ4

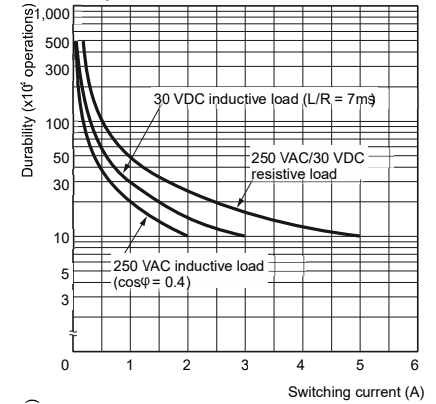

## G2R-2

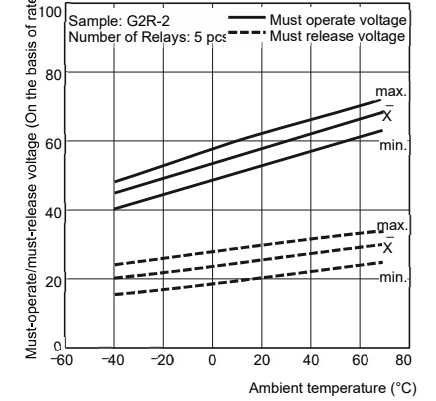

## ● Keep-power decrement with time G2RK-1

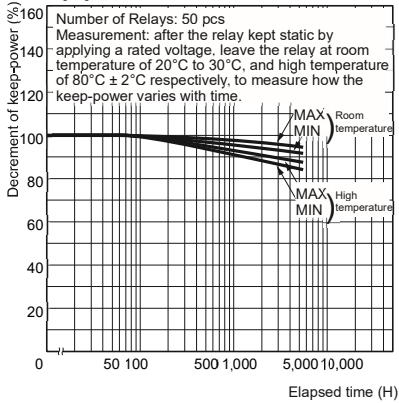

## ■ Dimensions

### Relays with PCB Terminals

(SPDT (1c) Relays)  
**G2R-1(-Z)**  
**G2R-1Z**

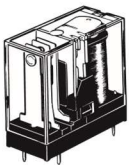

This illustration is the G2R-1 model.

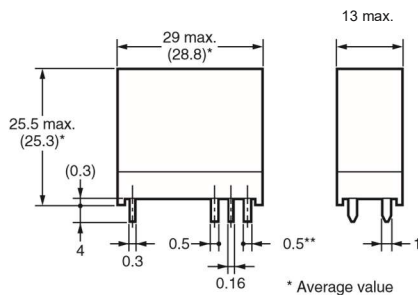

**PCB Mounting Holes**  
 (BOTTOM VIEW)  
 Tolerance: ±0.1 mm

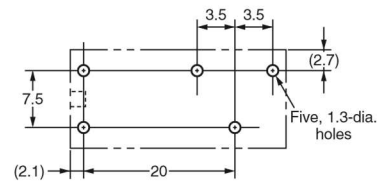

**Terminal Arrangement/ Internal Connections**  
 (BOTTOM VIEW)

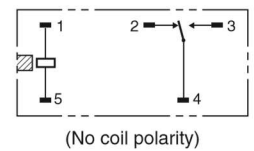

(12.7)\*



---

**G2R**

G2R-14(-Z)(-U)

Tolerance:  $\pm 0.1$  mm

**PCB Power Relay**

(BOTTOM VIEW)

**Relays with PCB Terminals  
(SPDT (1c) Relays)**

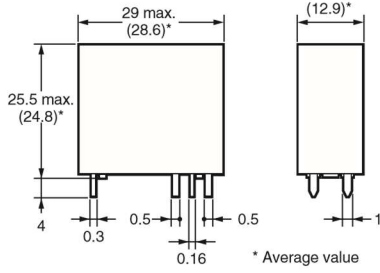

**PCB Mounting Holes  
(BOTTOM VIEW)**

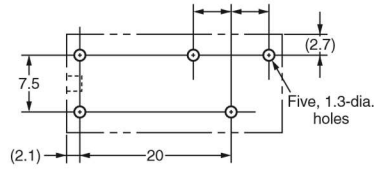

**Terminal Arrangement/  
Internal Connections**

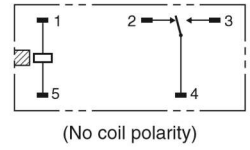

**G2R-124**

**Relays with PCB Terminals  
(SPST-NO (1a) Relays)  
G2R-1A4(-Z)(-U)  
G2R-1AZ4**

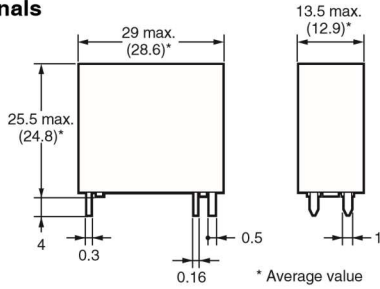

**PCB Mounting Holes  
(BOTTOM VIEW)  
Tolerance: ±0.1 mm**

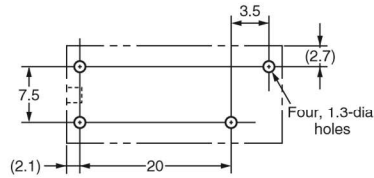

**Terminal Arrangement/  
Internal Connections  
(BOTTOM VIEW)**

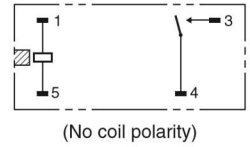

**Double-winding Latching Relays with  
PCB Terminals  
(SPDT (1c) Relays)  
G2RK-1**

G2R

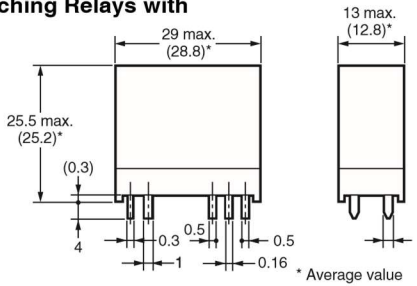
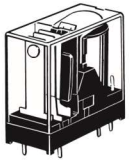

**PCB Mounting Holes  
(BOTTOM VIEW)  
Tolerance: ±0.1 mm**

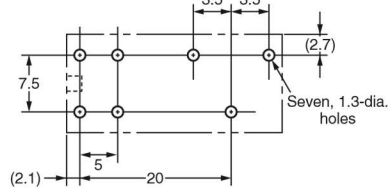

**Terminal Arrangement/  
Internal Connections  
(BOTTOM VIEW)**

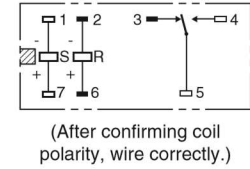

**Double-winding Latching Relays with  
PCB Terminals  
(SPST-NO (1a) Relays)  
G2RK-1A**

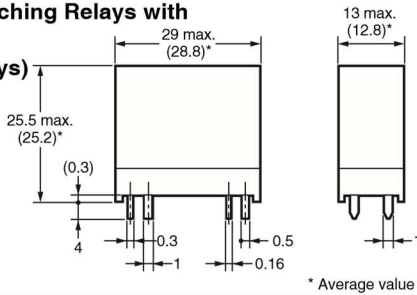
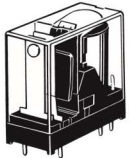

**PCB Mounting Holes  
(BOTTOM VIEW)  
Tolerance: ±0.1 mm**

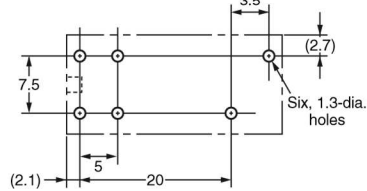

**Terminal Arrangement/  
Internal Connections  
(BOTTOM VIEW)**

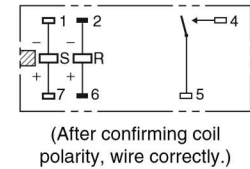

**Double-winding Latching Relays with PCB Terminals**

**PCB Mounting Holes  
3.5 3.5**

**Terminal Arrangement/**

# G2R

## (DPDT (2c) Relays) G2RK-2

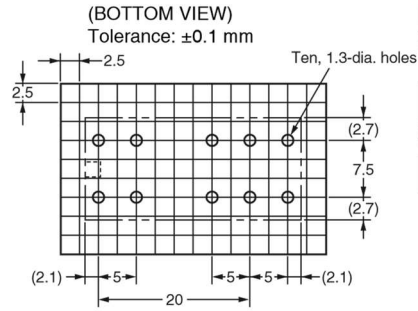
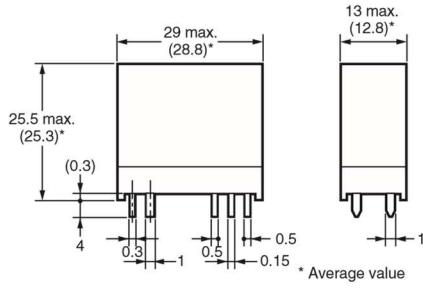
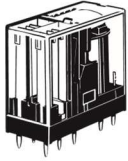

## PCB Power Relay

### Internal Connections (BOTTOM VIEW)

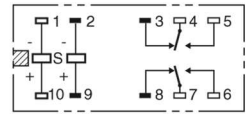

(After confirming coil polarity, wire correctly.)

## Double-winding Latching Relays with PCB Terminals (DPST-NO (2a) Relays) G2RK-2A

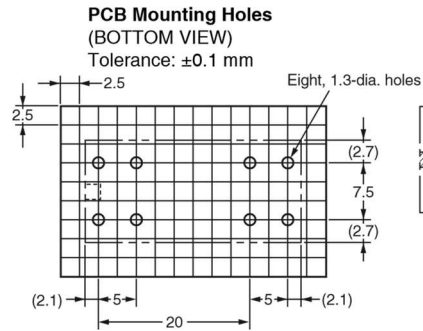
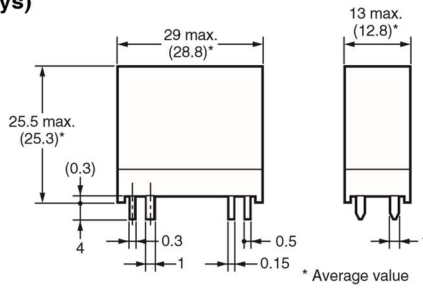
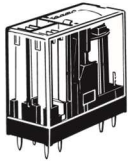

### Terminal Arrangement/ Internal Connections (BOTTOM VIEW)

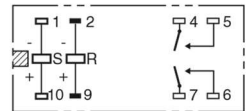

(After confirming coil polarity, wire correctly.)

Note: Orientation marks are indicated as follows: [ ] [ ] [ ]

2

R

9

# G2R

## PCB Power Relay

### Relays with PCB Terminals

#### G2R-2-H

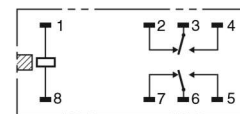
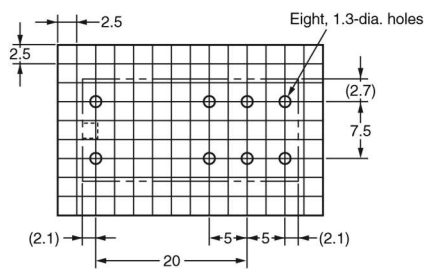
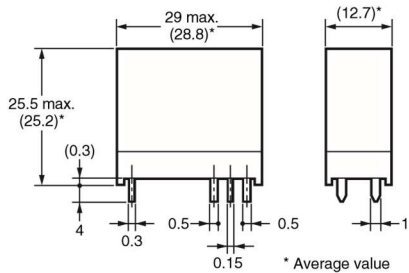
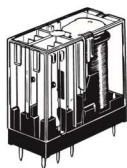

(No coil polarity)

### Relays with PCB Terminals

#### (DPST-NO (2a) Relays)

#### G2R-2A

#### G2R-2A-H

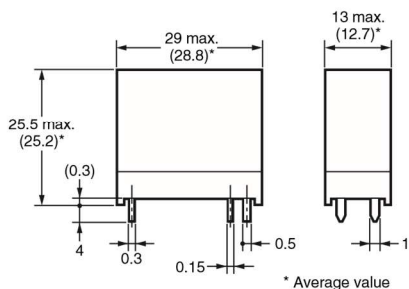

#### PCB Mounting Holes (BOTTOM VIEW)

Tolerance:  $\pm 0.1$  mm

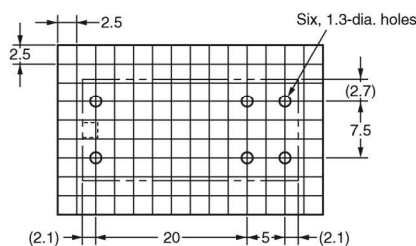

#### Terminal Arrangement/ Internal Connections (BOTTOM VIEW)



(No coil polarity)

### Relays with PCB Terminals

#### (DPDT (2c) Relays)

#### G2R-24(-Z)(-U)

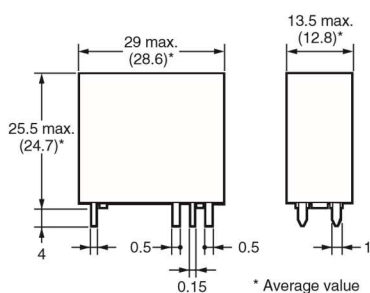

#### PCB Mounting Holes (BOTTOM VIEW)

Tolerance:  $\pm 0.1$  mm

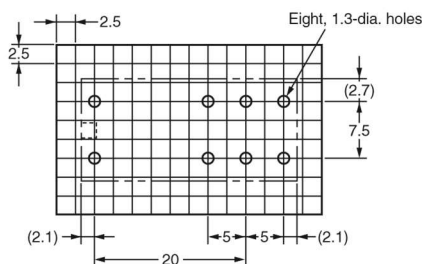

#### Terminal Arrangement/ Internal Connections (BOTTOM VIEW)

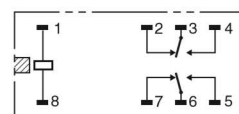

(No coil polarity)

### Relays with PCB Terminals

#### (DPST-NO (2a) Relays)

#### G2R-2A4(-Z)(-U)

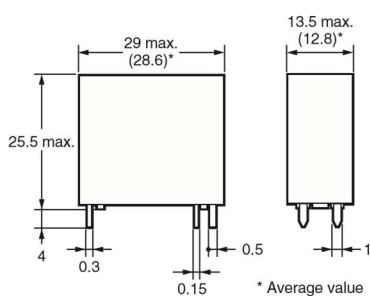

#### PCB Mounting Holes (BOTTOM VIEW)

Tolerance:  $\pm 0.1$  mm

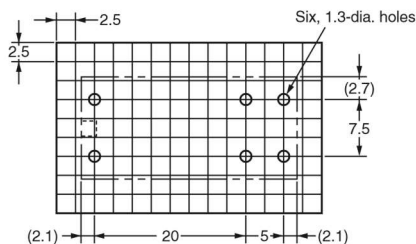

#### Terminal Arrangement/ Internal Connections (BOTTOM VIEW)

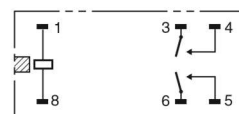

(No coil polarity)

#### (DPDT (2c) Relays)

#### G2R-2(-Z)

#### G2R-2A-Z

13 max.

#### PCB Mounting Holes (BOTTOM VIEW)

Tolerance:  $\pm 0.1$  mm

Note: Orientation marks are indicated as follows: [ ] [ ] [ ] [ ]

#### Terminal Arrangement/ Internal Connections (BOTTOM VIEW)

G  
2  
R

**G2R**  
**Relays with Quick-connect**  
**Terminals**  
**(SPDT (1c) Relays)**  
**G2R-1-T**

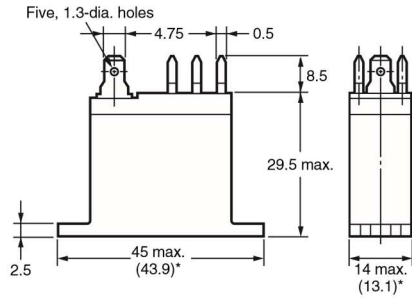
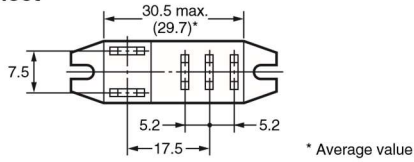
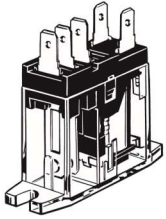

**Mounting Holes**  
**(BOTTOM VIEW)**  
 Tolerance:  $\pm 0.1$  mm

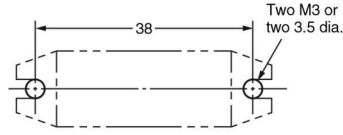

Note: Model number of quick-connect terminal is 187.

**PCB Power Relay**

**Terminal Arrangement/  
 Internal Connections**  
**(BOTTOM VIEW)**

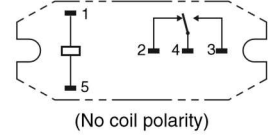

**Relays with Quick-connect**  
**Terminals**  
**(SPST-NO (1a) Relays)**  
**G2R-1A-T**

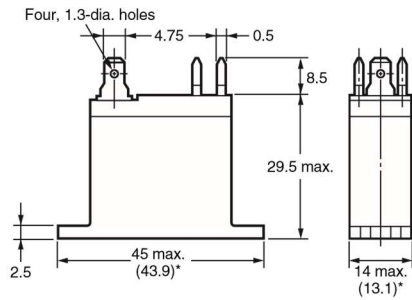
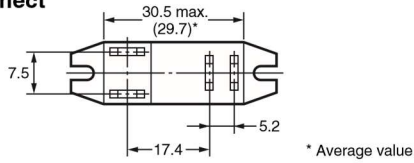
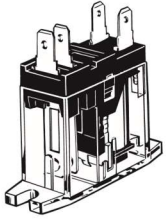

**Mounting Holes**  
**(BOTTOM VIEW)**  
 Tolerance:  $\pm 0.1$  mm

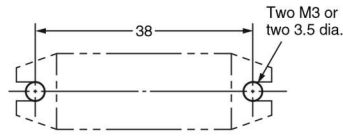

Note: Model number of quick-connect terminal is 187.

**Terminal Arrangement/  
 Internal Connections**  
**(BOTTOM VIEW)**

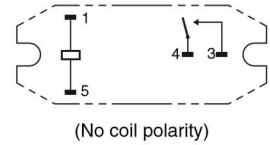

G2R

Note: Orientation marks are indicated as follows:

## Approved Standards

• The approval rating values for overseas standards are different from the performance values determined individually. Confirm the values before use.

**UL Recognized:**  File No. E41643

### 1-pole

Model	Contact form	Coil ratings	Contact ratings	Number of test operations
G2R-1A	SPST-NO (1a)	5 to 110 VDC 12 to 220 VAC	10 A, 250 VAC (General Use) at 40°C	100,000
G2R-1A4			5 A, 277 VAC (General Use) at 40°C	6,000
G2R-1A-H			10 A, 30 VDC (Resistive) at 40°C	100,000
G2R-1A-T			TV-3 (N. O. only) at 40°C	25,000
G2R-1			SPDT (1c)	5 to 110 VDC 12 to 220 VAC
G2R-1A4	5 A, 30 VDC (Resistive) at 40°C	6,000		
G2R-1Z	TV-3 (N. O. only) at 40°C	25,000		
G2R-1Z4				
G2R-1A-E	SPST-NO (1a)	5 to 110 VDC 12 to 220 VAC	16 A, 250 VAC (General Use) at 40°C	30,000
G2R-1-E	SPDT (1c)	5 to 110 VDC 12 to 220 VAC	16 A, 30 VDC (Resistive) at 40°C	6,000
			TV-3 (N. O. only) at 40°C	25,000

**CSA Certified:**  File No. LR31928

### 1-pole

Model	Contact form	Coil ratings	Contact ratings	Number of test operations
G2R-1A	SPST-NO (1a)	5 to 110 VDC 12 to 220 VAC	10 A, 250 VAC (General Use) at 40°C	100,000
G2R-1A4			10 A, 30 VDC (Resistive) at 40°C	100,000
G2R-1A-H			TV-3 (N. O. only) at 40°C	25,000
G2R-1A-T				
G2R-1	SPDT (1c)	5 to 110 VDC 12 to 220 VAC	5 A, 250 VAC (General Use) at 40°C	6,000
G2R-1A4			5 A, 30 VDC (Resistive) at 40°C	6,000
G2R-1Z				
G2R-1Z4				
G2R-1A-E	SPST-NO (1a)	5 to 110 VDC 12 to 220 VAC	16 A, 250 VAC (General Use) at 40°C	6,000
G2R-1-E	SPDT (1c)	5 to 110 VDC 12 to 220 VAC	16 A, 30 VDC (Resistive) at 40°C	6,000
			TV-3 (N. O. only) at 40°C	25,000

G  
2  
R

### 2-pole

Model	Contact form	Coil ratings	Contact ratings	Number of test operations
G2R-2A	DPST-NO (2a)	to 110 VDC to 220 VAC	A, 250 VAC (General Use) at 40°C	6,000
G2R-2A4			A, 30 VDC (Resistive) at 40°C	100,000
G2R-2A-H			TV-3 (N. O. only) at 40°C	25,000
G2R-2	DPDT (2c)	to 110 VDC to 220 VAC	TV-3 (N. O. only) at 40°C	25,000
G2R-24				
G2R-24-H				

### 2-pole

Model	Contact form	Coil ratings	Contact ratings	Number of test operations
G2R-2A	DPST-NO (2a)	to 110 VDC to 220 VAC	A, 250 VAC (General Use) at 40°C	6,000
G2R-2A4			A, 30 VDC (Resistive) at 40°C	100,000
G2R-2A-H			TV-3 (N. O. only) at 40°C	25,000
G2R-2	DPDT (2c)	to 110 VDC to 220 VAC	TV-3 (N. O. only) at 40°C	25,000
G2R-24				
G2R-24-H				

**EN/IEC, VDE Certified:**  Certificate No. 40015012

Model	Contact form	Coil ratings	Contact ratings	Number of test operations
G2R-1(A)-E	1	5, 6, 12, 24, 48, 100 VDC 12, 24, 100/110, 200/220 VAC	16 A, 250 VAC (cosφ = 1.0) at 70°C	
G2R-( )	1	5, 6, 12, 24, 48, 100 VDC 12, 24, 100/110, 200/220 VAC	10 A, 250 VAC (cosφ = 1.0) at 40°C	100,000
			10 A, 30 VDC (0 ms) at 40°C	
G2R-( )	2	5, 6, 12, 24, 48, 100 VDC 12, 24, 100/110, 200/220 VAC	5 A, 250 VAC (cosφ = 1.0) at 40°C	
			5 A, 30 VDC (0 ms) at 40°C	

EN, TÜV Certified: Registration No. R50030327

Model	Contact form	Coil ratings	Contact ratings	Number of test operations
G2R-1(A)-E	1	5 to 110 VDC 12 to 220 VAC	16 A, 250 VAC ( $\cos\phi = 1.0$ ) at 70°C	100,000
G2R-( )	1	5 to 110 VDC 12 to 220 VAC	10 A, 250 VAC ( $\cos\phi = 1.0$ ) at 70°C	
			10 A, 30 VDC (0 ms) at 70°C	
G2R-( )	2	5 to 110 VDC 12 to 220 VAC	5 A, 250 VAC ( $\cos\phi = 1.0$ ) at 40°C	
			5 A, 30 VDC (0 ms) at 40°C	

## Precautions

● Please refer to "PCB Relays Common Precautions" for correct use.

### Correct Use

#### ● Mounting

- When mounting a number of relays on a PCB, be sure to provide a minimum mounting space of 5 mm between the two juxtaposed relays as shown

below. ● If a double-winding latching Relay is

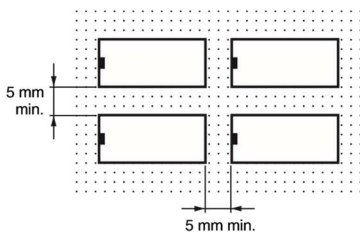

used will semi-time Note:

Type	Receptacle terminals	Positive housing
#187 (Width 4.75)	AMP170330-1 (170324-1)	AMP172074-1 (natural color)
	AMP170331-1 (170325-1)	AMP172074-4 (yellow)
	AMP170332-1 (170326-1)	AMP172074-5 (green)
		AMP172074-6 (blue)

Refer to the following table for examples of positive-lock connectors made by AMP. Contact the manufacturer directly for details on connectors including availability.

Therefore, do not use the Relay in a strong magnetic field environment.

#### ● Degradation over Time of Doublewinding Latching Relays Holding Ability

left set for an extended period, changes over time degrade the magnetic force, and the reduction in holding ability may cause the set status to be released. This is also because of the properties of hard magnetic material, and the rate of degradation over depends on the

#### ● Handling

air-feeding.

ambient environment (e.g.,

- The terminals are compatible with ● Minimum Pulse Width of Double-winding Latching Relays temperature, humidity, vibration, and Faston receptacle #187 and are winding Latching Relays presence or absence of external suitable for positive-lock mounting. ● The minimum pulse width shown in

# G2R

G  
2  
R

Use only Faston terminals with the specified numbers.  
 Select leads for connecting Faston receptacles with wire diameters that are within the allowable range for the load current.  
 Do not apply excessive force to the terminals when mounting or dismantling the Faston receptacle. Also, do not insert terminals at an angle, or insert/remove multiple terminals at the same time. Be sure to insert and remove terminals carefully one at a time.

the table of characteristics are values measured under conditions of ambient temperature at 23°C with rated operating voltage imposed on coil. The Relay may not provide a satisfactory performance as its holding ability decreases depending on the operating circuit conditions and ambient temperature, or decreases due to degradation over time. In actual operation, impose to the coil a rated operating voltage with a pulse width that is suitable to the actual load, and reset the setting at least once a year, to correspond to the degradation over time.

- When using the Relay in a strong magnetic field environment, the magnetic body may be demagnetized due to the influence of environment, causing the Relay to malfunction.

## PCB Power Relay

magnetic fields). Perform maintenance at least once a year by resetting, applying the rated voltage again, and then setting.

### ●Wiring High Capacity (-E) Models

- High-capacity models (-E) have a structure that connects two terminals from one contact.

When designing the circuit, use both terminals.

If you use only one terminal, the relay may be unable to satisfy specified performance.

Please check each region's Terms & Conditions by region website.

## OMRON Corporation

Electronic and Mechanical Components Company

### Regional Contact

#### Americas

<https://www.components.omron.com/>

#### Asia-Pacific

<https://ecb.omron.com.sg/>

#### Korea

<https://www.omron-ecb.co.kr/>

#### Europe

<http://components.omron.eu/>

#### China

<https://www.ecb.omron.com.cn/>

#### Japan

<https://www.omron.co.jp/ecb/>

© OMRON Corporation 2007-2018 All Rights Reserved.

In the interest of product improvement, specifications are subject to change without notice.

Cat. No. K013-E1-20

0818(0207)(O)