



الحمادي للإلكترونيات  
ALHAMMADI FOR ELECTRONICS

## Instructions for duinotech I2C module

### Introduce:

This Arduino Tiny RTC I2C module incorporates the DS1307 I2C real time clock IC and the 24C32 32K I2C EEPROM storage. What's more, it has a DS18B20 temperature sensor on board.

Arduino Tiny RTC I2C Real Time Clock Pinout

PIN	Description	Comment
BAT	Battery voltage	To monitor the battery voltage, or not connected
GND	Ground	Ground
VCC	5V supply	Power the module and charge the battery
SDA	I2C data	I2C data for the RTC
SCL	I2C clock	I2C clock for the RTC
DS	DS18B20 Temp. Sensor output	One wire interface
SQ	Square wave output	Normally not used

The I2C wires "SDA" and "SCL" are the data line and clock line, they should be connected to the corresponding pins depending on the Arduino board.

Board	I2C / TWI pins
Uno, Ethernet	A4 (SDA), A5 (SCL)
Mega2560	20 (SDA), 21 (SCL)
Leonardo	2 (SDA), 3 (SCL)
Due	20 (SDA), 21 (SCL), SDA1, SCL1

Example code:

There are three examples code for the RTC , the EEPROM, and the DS18B20 temperature sensor. Only the DS18B20 temperature sensor's example, the DS pinout is used.

Wire connection as below:

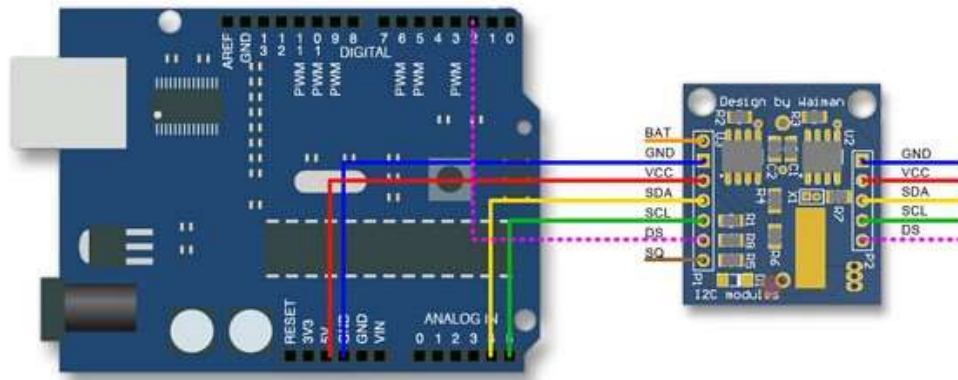

And the corresponding libraries are attached.

### First example for the RTC:

```
#include <Wire.h>
#include <RTClib.h>
```

```
void printDateTime(DateTime dateTime);
```

```
RTC_DS1307 RTC;
```

```
void setup (void){
  Serial.begin(9600);
  Wire.begin();
  RTC.begin();
}
```

```
void loop() {
  if (Serial.available() > 0) {

    int instruct = Serial.read();

    switch (instruct) {
    case 'D': {
      DateTime now = RTC.now();
```

```

    printDateTime(now);
    break;
} case 'S':
    RTC.set(RTC_MONTH, 6);
    RTC.set(RTC_HOUR, 16);
    break;
}
}
}

void printDateTime(DateTime dateTime) {
    Serial.print(dateTime.year(), DEC);
    Serial.print('/');
    Serial.print(dateTime.month(), DEC);
    Serial.print('/');
    Serial.print(dateTime.day(), DEC);
    Serial.print(' ');
    Serial.print(dateTime.hour(), DEC);
    Serial.print(':');
    Serial.print(dateTime.minute(), DEC);
    Serial.print(':');
    Serial.print(dateTime.second(), DEC);
    Serial.println();
}

```

## Second example for the EEPROM:

```

#include <Wire.h>
#include <AT24Cxx.h>
#include <RTClib.h>

AT24Cxx AT24C32(0x50);
RTC_DS1307 RTC;

void setup (void){
    Serial.begin(9600);
    Wire.begin(); RTC.begin();
}

```

```

void loop() {
  if
  (Serial.available() > 0) {
    int instruct = Serial.read();

    switch (instruct) {
    case 'P':
      {
        AT24C32.WriteMem(0, 0x04);
        break;
      }
    case 'G':
      {
        char buffer[3];
        AT24C32.ReadMem(0, buffer, 3);
        Serial.print(2000 + buffer[2], DEC);
        Serial.print('/');
        Serial.print(buffer[1], DEC);
        Serial.print('/');
        Serial.print(buffer[0], DEC);
        Serial.println();
        break;
      }
    case 'F':
      {
        DateTime now = RTC.now();
        char buffer[3];
        buffer[0] = now.day();
        buffer[1] = now.month();
        buffer[2] = now.year() - 2000;
        AT24C32.WriteMem(0, buffer, 3);
        break;
      }
    }
  }
}

```

### Third example for the LM75:

```

#include <Wire.h>
#include <LM75.h>

```

```
LM75 sensor(LM75_ADDRESS | 0b000); const  
int OSPIN = 6;
```

```
void setup (void){  
  pinMode(OSPIN, INPUT);
```

```
  Serial.begin(9600);  
  Wire.begin();  
  sensor.tos(47.5);  
  sensor.thyst(42);
```

```
}
```

```
void loop() { if  
(Serial.available() > 0) {  
  int instruct = Serial.read();  
  int OSValue = HIGH;  
  OSValue = digitalRead(OSPIN);  
  if (OSValue == LOW)  
    Serial.println("Over heating!");
```

```
  switch (instruct) {  
  case 'T':  
    Serial.print("Current temp: ");  
    Serial.print(sensor.temp());  
    Serial.println(" C");  
    break;
```

```
  }  
}  
}
```